



# Product Specification

AU OPTRONICS CORPORATION

- ( ) Preliminary Specifications
- (V) Final Specifications

<b>Module</b>	15.4" WXGA+ Color TFT-LCD
<b>Model Name</b>	B154PW04 V6

<b>Customer</b>	<b>Date</b>
<b>Checked &amp; Approved by</b>	<b>Date</b>
_____	_____

<b>Approved by</b>	<b>Date</b>
_____	_____
<b>Prepared by</b>	<b>Date</b>
_____	_____

Note: This Specification is subject to change without notice.

**NBBU Marketing Division / AU Optronics corporation**



**Contents**

**1. Handling Precautions ..... 4**

**2. General Description ..... 5**

    2.1 General Specification .....5

    2.2 Optical Characteristics .....6

**3. Functional Block Diagram ..... 11**

**4. Absolute Maximum Ratings..... 12**

    4.1 Absolute Ratings of TFT LCD Module ..... 12

    4.2 Absolute Ratings of Backlight Unit..... 12

    4.3 Absolute Ratings of Environment ..... 12

**5. Electrical characteristics ..... 13**

    5.1 TFT LCD Module..... 13

    5.2 Backlight Unit ..... 15

**6. Signal Characteristic ..... 167**

    6.1 Pixel Format Image ..... 16

    6.2 The input data format ..... 18

    6.3 Signal Description/Pin Assignment ..... 19

    6.4 Interface Timing ..... 21

**7. Connector Description..... 24**

    7.1 TFT LCD Module..... 24

**8. Dynamic Test ..... 25**

    8.1 Vibration Test ..... 25

    8.2 Shock Test Spec:..... 25

**9. Reliability..... 26**

**10. Mechanical Characteristics..... 27**

    10.1 LCM Outline Dimension..... 27

    10.2 Screw Hole Depth and Center Position..... 29

**11. Shipping and Package ..... 30**

    11.1 Shipping Label Format ..... 30

    11.2 Carton package ..... 30

    11.3 Shipping package of palletizing sequence ..... 30

**12. Appendix: EDID description ..... 31**



# Product Specification

AU OPTRONICS CORPORATION

## Record of Revision

Version and Date	Page	Old description	New Description	Remark
0.1 2007/12/7	All	First Edition for Customer		



### 1. Handling Precautions

- 1) Since front polarizer is easily damaged, pay attention not to scratch it.
- 2) Be sure to turn off power supply when inserting or disconnecting from input connector.
- 3) Wipe off water drop immediately. Long contact with water may cause discoloration or spots.
- 4) When the panel surface is soiled, wipe it with absorbent cotton or other soft cloth.
- 5) Since the panel is made of glass, it may break or crack if dropped or bumped on hard surface.
- 6) Since CMOS LSI is used in this module, take care of static electricity and insure human earth when handling.
- 7) Do not open nor modify the Module Assembly.
- 8) Do not press the reflector sheet at the back of the module to any directions.
- 9) In case if a Module has to be put back into the packing container slot after once it was taken out from the container, do not press the center of the LED lamp Reflector edge. Instead, press at the far ends of the LED lamp Reflector edge softly. Otherwise the TFT Module may be damaged.
- 10) At the insertion or removal of the Signal Interface Connector, be sure not to rotate nor tilt the Interface Connector of the TFT Module.
- 11) After installation of the TFT Module into an enclosure (Notebook PC Bezel, for example), do not twist nor bend the TFT Module even momentary. At designing the enclosure, it should be taken into consideration that no bending/twisting forces are applied to the TFT Module from outside. Otherwise the TFT Module may be damaged.
- 12) Small amount of materials having no flammability grade is used in the LCD module. The LCD module should be supplied by power complied with requirements of Limited Power Source (IEC60950 or UL1950), or be applied exemption.
- 13) The LCD module is designed so that the LED in it is supplied by Limited Current Circuit (IEC60950 or UL1950). Do not connect the LED in Hazardous Voltage Circuit.



## Product Specification

AU OPTRONICS CORPORATION

### 2. General Description

B154PW04 V6 is a Color Active Matrix Liquid Crystal Display composed of a TFT LCD panel, a driver circuit, and backlight system. The screen format is intended to support the WXGA+ (1440(H) x 900(V)) screen and 262k colors (RGB 6-bits data driver) without backlight inverter. All input signals are LVDS interface compatible.

B154PW04 V6 is designed for a display unit of notebook style personal computer and industrial machine.

### 2.1 General Specification

The following items are characteristics summary on the table at 25 °C condition:

Items	Unit	Specifications			
Screen Diagonal	[mm]	391 (15.4W")			
Active Area	[mm]	331.560 (H) X 207.225 (V)			
Pixels H x V		1440x3(RGB) x 900			
Pixel Pitch	[mm]	0.23025X0.23025			
Pixel Format		R.G.B. Vertical Stripe			
Display Mode		Normally White			
White Luminance (ILED=19mA) Note: ILED is lamp current	[cd/m <sup>2</sup> ]	300 typ.(160 points average) 270 min.(160 points average) (Note1)			
Luminance Uniformity		2 max. (160 points)			
Contrast Ratio		500 typ			
Response Time	[ms]	16 typ			
Nominal Input Voltage VDD	[Volt]	+3.3 typ.			
Power Consumption	[Watt]	5.8 max.			
Weight	[Grams]	450 max.			
Physical Size	[mm]		L	W	T
		Max	344.3	222.3	6.1
		Typical	344.0	222.0	-
		Min	343.7	221.7	-
Electrical Interface		Dual channel LVDS			
Surface Treatment		Anti-Glare, Hardness 3H,			



## Product Specification

AU OPTRONICS CORPORATION

Support Color		262K colors ( RGB 6-bit )
Temperature Range Operating Storage (Non-Operating)	[°C] [°C]	0 to +50 -25 to +65
RoHS Compliance		RoHS Compliance

### 2.2 Optical Characteristics

The optical characteristics are measured under stable conditions at 25°C (Room Temperature) :

Item	Unit	Conditions	Min.	Typ.	Max.	Note
White Luminance ILED=19mA	[cd/m <sup>2</sup> ]	160 points average	270	300	-	1, 4, 5.
Viewing Angle	[degree]	Horizontal (Right) CR = 10 (Left)	60	65	-	9
	[degree]		60	65	-	
	[degree] [degree]	Vertical (Upper) CR = 10 (Lower)	50 60	55 65	- -	
Luminance Uniformity		160 Points	-	-	2	1, 2, 4
WNU		Any one point among 160 Points	-	-	2	1, 2, 4
CR: Contrast Ratio			400	500	-	1, 4, 6
Cross talk	%				4	7
Response Time	[msec]	Rising	-	8	12	8
	[msec]	Falling	-	23	28	
	[msec]	Rising + Falling	-	31	40	
Chromaticity of color Coordinates (CIE 1931)		Red x	0.580	0.600	0.620	1,3,4
		Red y	0.325	0.345	0.365	
		Green x	0.300	0.320	0.340	
		Green y	0.535	0.555	0.575	
		Blue x	0.130	0.150	0.170	
		Blue y	0.100	0.120	0.140	
		White x	0.293	0.313	0.333	
		White y	0.309	0.329	0.349	
NTSC	%	CIE 1931	-	45	-	



# Product Specification

AU OPTRONICS CORPORATION

Note 1: 160 points position (Ref: Active area)

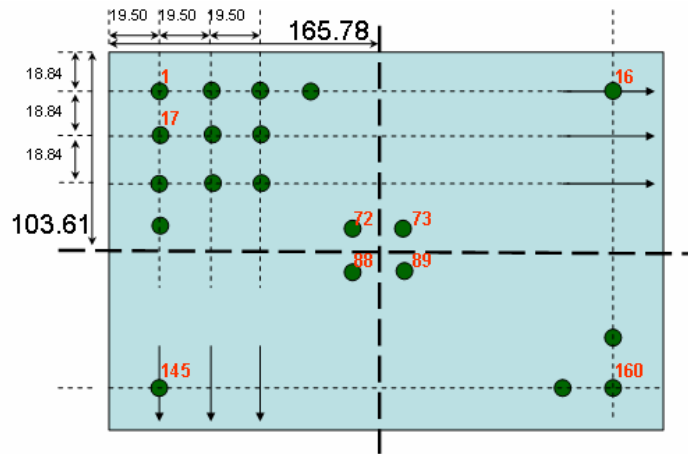

Note 2: The luminance uniformity of 160 points is defined by dividing the maximum luminance values by the minimum test point luminance

$$\delta_{w160} = \frac{\text{Maximum Brightness of thirteen points}}{\text{Minimum Brightness of thirteen points}}$$

Worst Neighbor Luminance Uniformity (The 4 points that are closest to the test point)

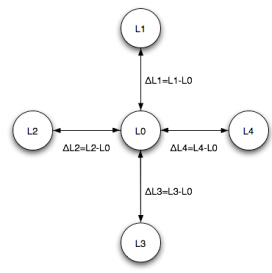

$$WNU = 100\% - \text{Max}(L1, L2, L3, L4) / L0$$

$$\text{Global WNU} = \min(WNU1, \dots, WNU160)$$

Note 3: Chromaticity of color Coordinates

Chromaticity is defined by the average of the color performance of points 72, 73, 88, 89

$$\text{Color}_{\text{center}} = (\text{Color}_{72} + \text{Color}_{73} + \text{Color}_{88} + \text{Color}_{89}) / 4$$

Note 4: Measurement method

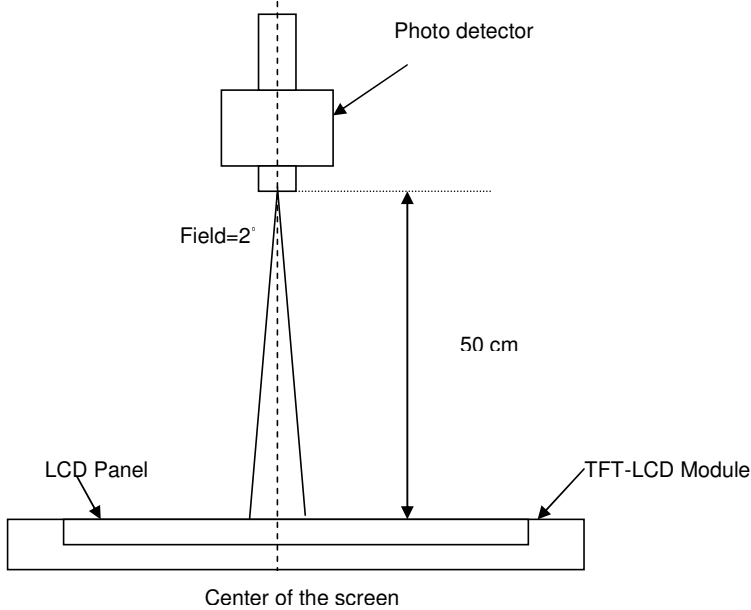

The LCD module should be stabilized at given temperature for 30 minutes to avoid abrupt temperature change during measuring. In order to stabilize the luminance, the measurement should be executed after lighting Backlight for 30 minutes in a stable, windless and dark room.

Note 5 : Definition of Average Luminance of White ( $Y_L$ ):

$$Y_L = \text{SUM}(L1:L160) / 160$$

where L1 to L160 are the luminance values measured at point #1 to #160.

Note 6 : Definition of contrast ratio:

Contrast ratio is calculated with the following formula.

$$\text{Contrast ratio (CR)} = \frac{\text{Brightness of point 72 on the "White" state}}{\text{Brightness of point 72 on the "Black" state}}$$



Note 7 : Definition of Cross Talk (CT)

$$CT = |Y_B - Y_A| / Y_A \times 100 (\%)$$

Where

$Y_A$  = Luminance of measured location without gray level 0 pattern (cd/m<sup>2</sup>)

$Y_B$  = Luminance of measured location with gray level 0 pattern (cd/m<sup>2</sup>)

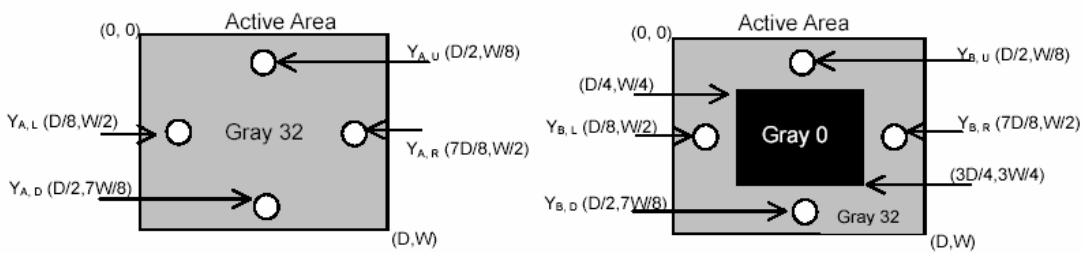

Note 8: Definition of response time:

The output signals of BM-7 or equivalent are measured when the input signals are changed from "Black" to "White" (falling time) and from "White" to "Black" (rising time), respectively. The response time interval between the 10% and 90% of amplitudes. Refer to figure as below.

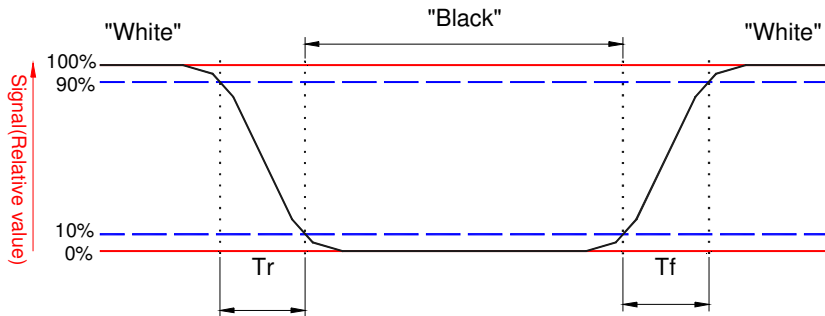



## Product Specification

AU OPTRONICS CORPORATION

### Note 9. Definition of viewing angle

Viewing angle is the measurement of contrast ratio  $\geq 10$ , at the screen center, over a  $180^\circ$  horizontal and  $180^\circ$  vertical range (off-normal viewing angles). The  $180^\circ$  viewing angle range is broken down as follows;  $90^\circ$  ( $\theta$ ) horizontal left and right and  $90^\circ$  ( $\Phi$ ) vertical, high (up) and low (down). The measurement direction is typically perpendicular to the display surface with the screen rotated about its center to develop the desired measurement viewing angle.

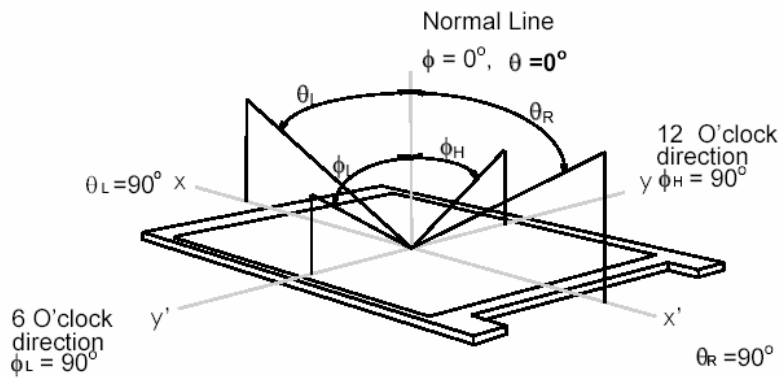

## 3. Functional Block Diagram

The following diagram shows the functional block of the 15.4 inches wide Color TFT/LCD Module:

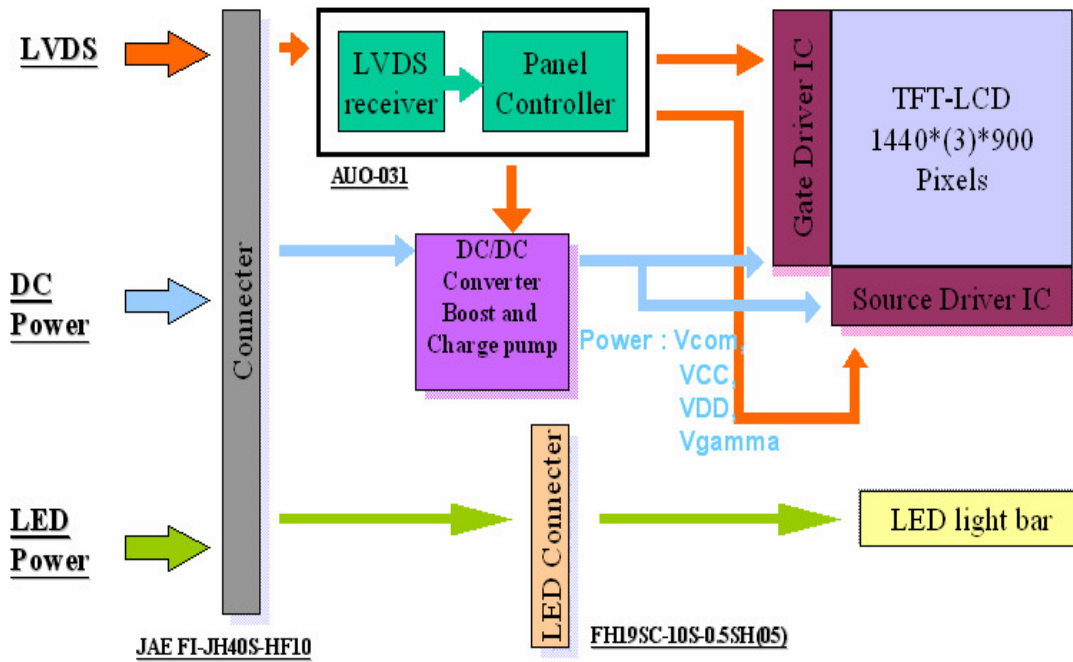



# Product Specification

AU OPTRONICS CORPORATION

## 4. Absolute Maximum Ratings

An absolute maximum rating of the module is as following:

### 4.1 Absolute Ratings of TFT LCD Module

Item	Symbol	Min	Max	Unit	Conditions
Logic/LCD Drive Voltage	Vin	-0.3	+4.0	[Volt]	Note 1,2

### 4.2 Absolute Ratings of Backlight Unit

Item	Symbol	Min	Max	Unit	Conditions
LED Current	ILED	-	20	[mA] rms	Note 1,2

### 4.3 Absolute Ratings of Environment

Item	Symbol	Min	Max	Unit	Conditions
Operating Temperature	TOP	0	+50	[°C]	Note 3
Operation Humidity	HOP	5	95	[%RH]	Note 3
Storage Temperature	TST	-20	+60	[°C]	Note 3
Storage Humidity	HST	5	95	[%RH]	Note 3

Note 1: At Ta (25°C )

Note 2: Permanent damage to the device may occur if exceed maximum values

**Note 3: For quality performance, please refer to AUO IIS (Incoming Inspection Standard).**

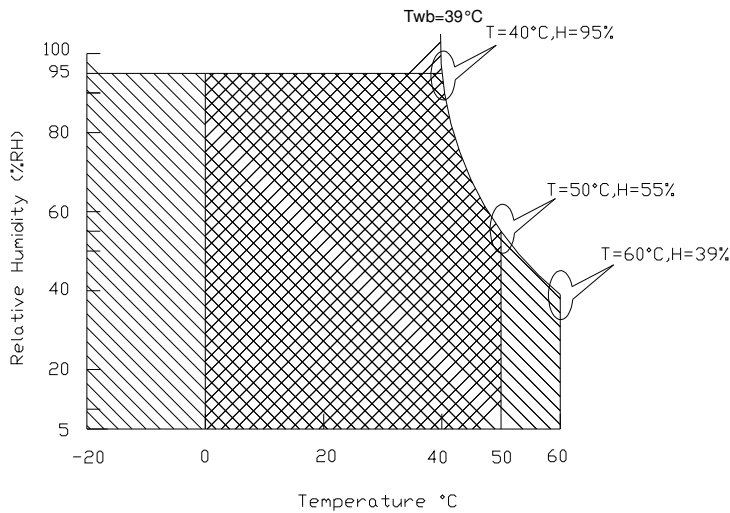

Operating Range Storage Range +

## 5. Electrical characteristics

### 5.1 TFT LCD Module

#### 5.1.1 Power Specification

Input power specifications are as follows;

Symble	Parameter	Min	Typ	Max	Units	Note
VDD	Logic/LCD Drive Voltage	3.0	3.3	3.6	[Volt]	
PDD	VDD Power			1.7	[Watt]	Note 1
IDD	IDD Current		400	500	[mA]	Note 1
IRush	Inrush Current			2000	[mA]	Note 2
VDDrp	Allowable Logic/LCD Drive Ripple Voltage			100	[mV] p-p	

Note 1 : Maximum Measurement Condition : Black Pattern

Note 2 : Typical Measurement Condition: Mosaic Pattern

Note 3 : Measure Condition

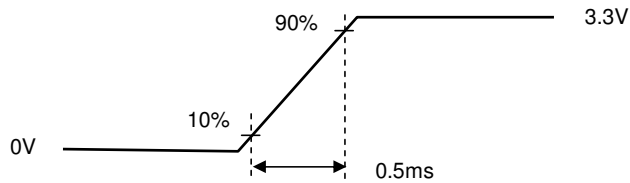
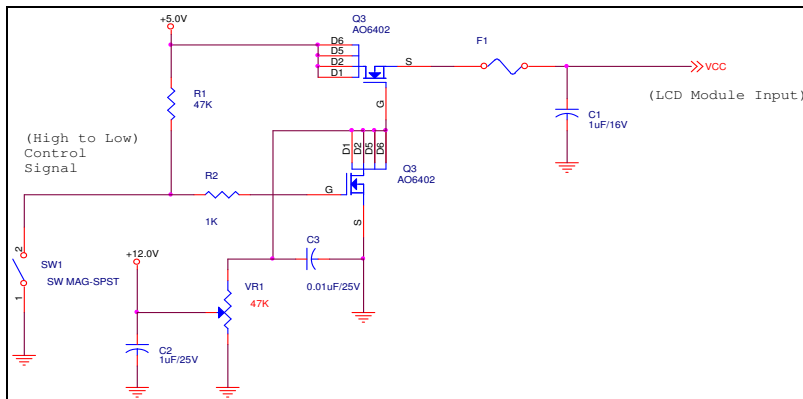

## 5.1.2 Signal Electrical Characteristics

Input signals shall be low or High-impedance state when VDD is off.

It is recommended to refer the specifications of THC63LVDF84A (Thine Electronics Inc.) in detail.

Signal electrical characteristics are as follows;

Parameter	Condition	Min	Max	Unit
Vth	Differential Input High Threshold (Vcm=+1.2V)	-	100	[mV]
Vtl	Differential Input Low Threshold (Vcm=+1.2V)	-100	-	[mV]
Vcm	Differential Input Common Mode Voltage	1.1	1.45	[V]

Note: LVDS Signal Waveform

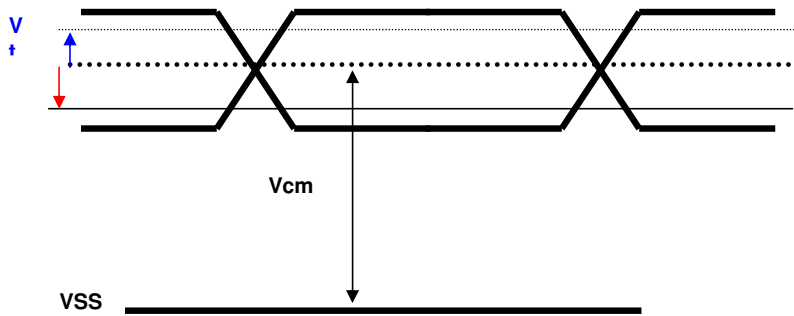



# Product Specification

AU OPTRONICS CORPORATION

## 5.2 Backlight Unit

The BLU system is an edge type light source with LED (Light Emitting Diode) light bar

The BLU system is an edge type light source with LED (Light Emitting Diode) light bar

Item	Symbol	Min.	Typ.	Max.	Unit	Note
Fixed input current	IL <sub>t</sub>				mA <sub>rms</sub>	Absolute maximum guarantee current
Input current	IL		20		mA <sub>rms</sub>	Current for each LED
Light bar Voltage	VL		3.3		V <sub>rms</sub>	
Light bar Power	PL		3.96		Watt	PL= ILxVLxLED NUMBER

Light bar PIN assignment:

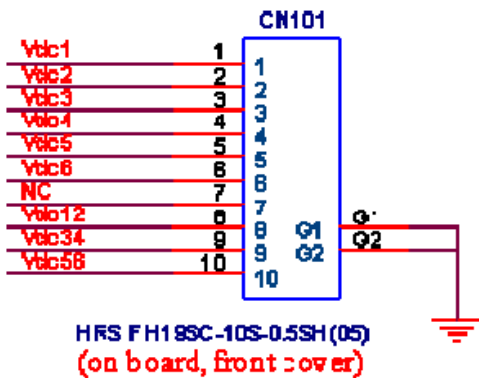

PIN NO.	SYMBOL	FUNCTION
1	Vdc1	LED Cathode (Negative)
2	Vdc2	LED Cathode (Negative)
3	Vdc3	LED Cathode (Negative)
4	Vdc4	LED Cathode (Negative)
5	Vdc5	LED Cathode (Negative)
6	Vdc6	LED Cathode (Negative)
7	NC	NC
8	Vdc(1&2)	LED Anode (Positive)
9	Vdc(3&4)	LED Anode (Positive)
10	Vdc(5&6)	LED Anode (Positive)

## 6. Signal Characteristic

### 6.1 Pixel Format Image

Following figure shows the relationship of the input signals and LCD pixel format.

Pixel Format on the Display

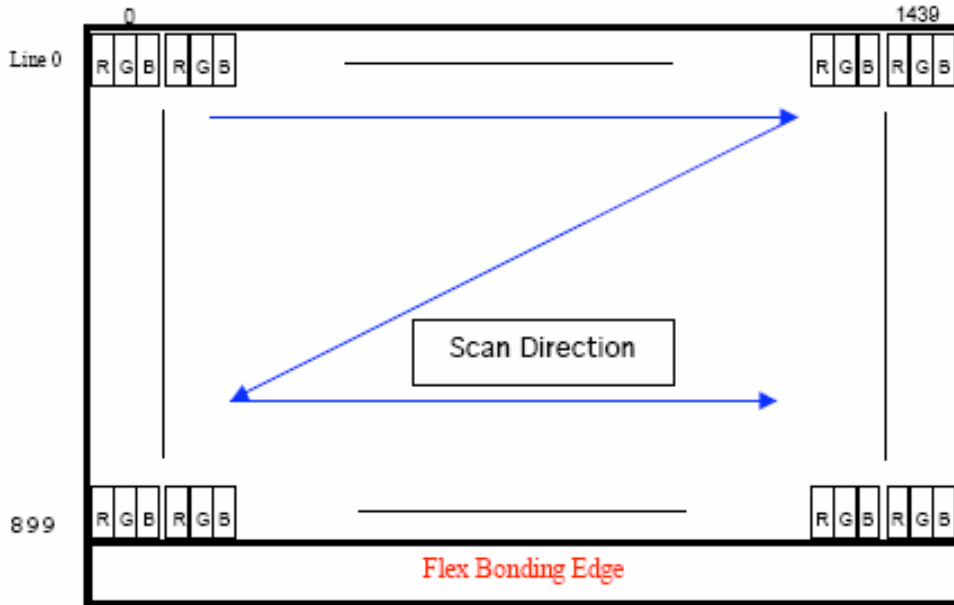



## 6.2 The input data format

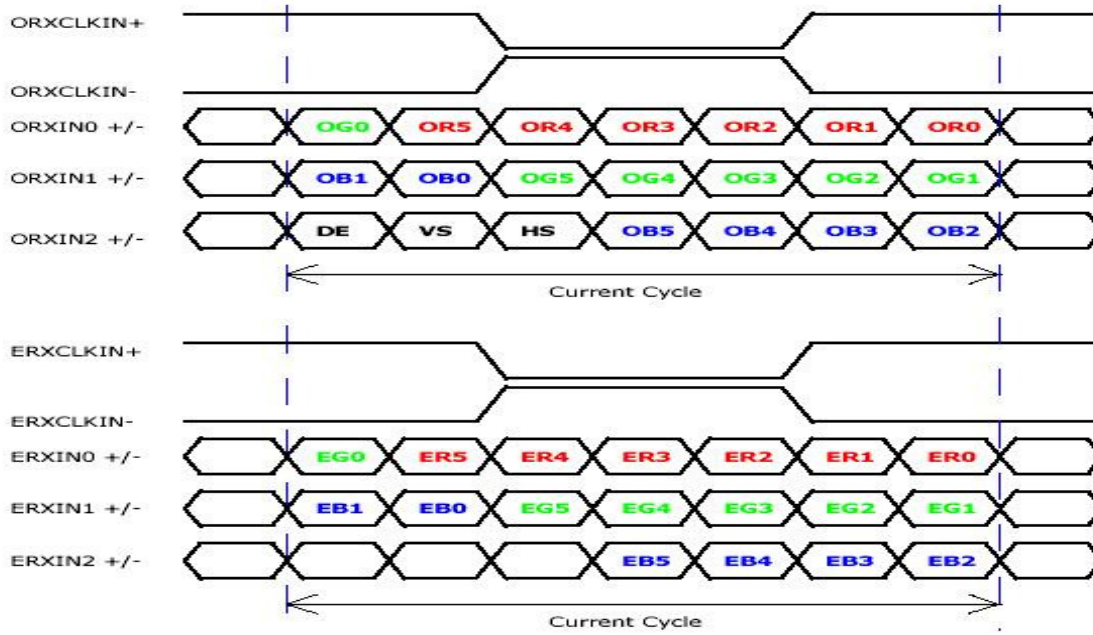

Signal Name	Description
VEEDID (3.3V)	+3.3V EDID Power
CLK EEDID	EDID Clock Input
DATA EEDID	EDID Data Input
ORXIN0-, ORXIN0+	Odd LVDS differential data input(ORed0-ORed5, OGreen0)
ORXIN1-, ORXIN1+	Odd LVDS differential data input(OGreen1-OGreen5, OBlue0-ORed1)
ORXIN2-, ORXIN2+	Odd LVDS differential data input(OBlue2-OBlue5, Hsync, Vsync, DE)
ORXCLKIN-, ORXCLKIN+	Odd LVDS differential clock input
ERXIN0-, ERXIN0+	Even LVDS differential data input(ERed0-ERed5, EGreen0)
ERXIN1-, ERXIN1+	Even LVDS differential data input(EGreen1-EGreen5, EBlue0-EBlue1)
ERXIN2-, ERXIN2+	Even LVDS differential data input(EBlue2-EBlue5)
ERXCLKIN-, ERXCLKIN+	Even LVDS differential clock input
VDD	+3.3V Power Supply
VSS	Ground

Note: Output signals from any system shall be low or High-impedance state when VDD is off.

## 6.3 Signal Description/Pin Assignment

LVDS is a differential signal technology for LCD interface and high speed data transfer device.

Pin	Symbol	Description	Micro-coax cable gauge (AWG)
1	GND	Ground	40
2	Vcc	Power Supply (+3.3V)	<b>36</b>
3	Vcc	Power Supply (+3.3V)	<b>36</b>
4	VEDID	DDC 3.3V Power	40
5	Vcc	Power Supply (+3.3V)	36
6	ClkEDID	DDC Clock	40
7	DATAEDID	DDC Data	40
8	Odd_Rin0-	Odd Channel Differential Data Input	40
9	Odd_Rin0+	Odd Channel Differential Data Input	40
10	GND	Ground	40
11	Odd_Rin1-	Odd Channel Differential Data Input	40
12	Odd_Rin1+	Odd Channel Differential Data Input	40
13	GND	Ground	40
14	Odd_Rin2-	Odd Channel Differential Data Input	40
15	Odd_Rin2+	Odd Channel Differential Data Input	40
16	GND	Ground	40
17	Odd_Clkin-	Odd Channel Differential Clock Input	40
18	Odd_Clkin+	Odd Channel Differential Clock Input	40
19	GND	Ground	40
20	Even_Rin0-	Even Channel Differential Data Input	40
21	Even_Rin0+	Even Channel Differential Data Input	40
22	GND	Ground	40
23	Even_Rin1-	Even Channel Differential Data Input	40
24	Even_Rin1+	Even Channel Differential Data Input	40
25	GND	Ground	40
26	Even_Rin2-	Even Channel Differential Data Input	40
27	Even_Rin2+	Even Channel Differential Data Input	40
28	GND	Ground	40
29	Even_Clkin-	Even Channel Differential Clock Input	40
30	Even_Clkin+	Even Channel Differential Clock Input	40
31	Vdc1	LED Cathode (Negative)	40
32	Vdc2	LED Cathode (Negative)	40
33	Vdc3	LED Cathode (Negative)	40
34	Vdc4	LED Cathode (Negative)	40
35	Vdc5	LED Cathode (Negative)	40
36	Vdc6	LED Cathode (Negative)	40

37	AGINE	Panel self test	40
38	Vdc(1,2,3,4,5,6)	LED Annold (Positive)	40
39	Vdc(1,2,3,4,5,6)	LED Annold (Positive)	40
40	Vdc(1,2,3,4,5,6)	LED Annold (Positive)	40

**Note1: Start from right side**

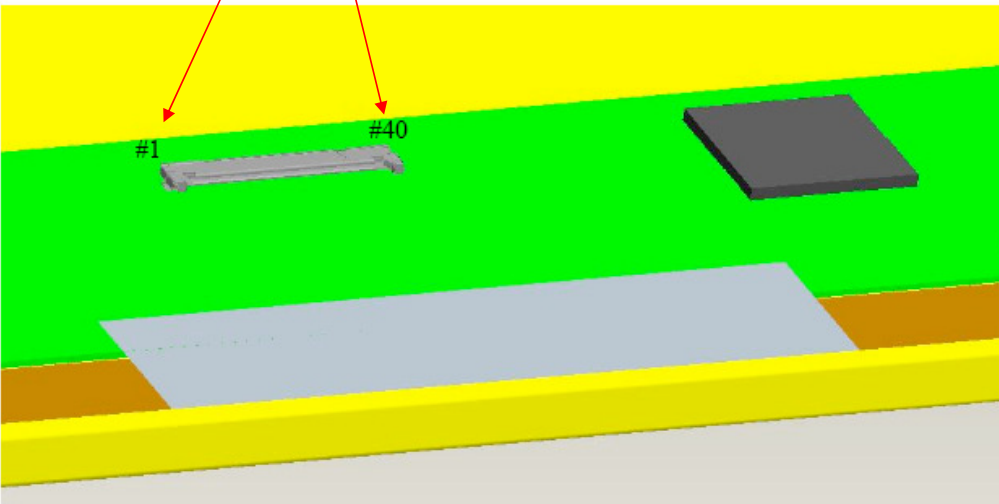
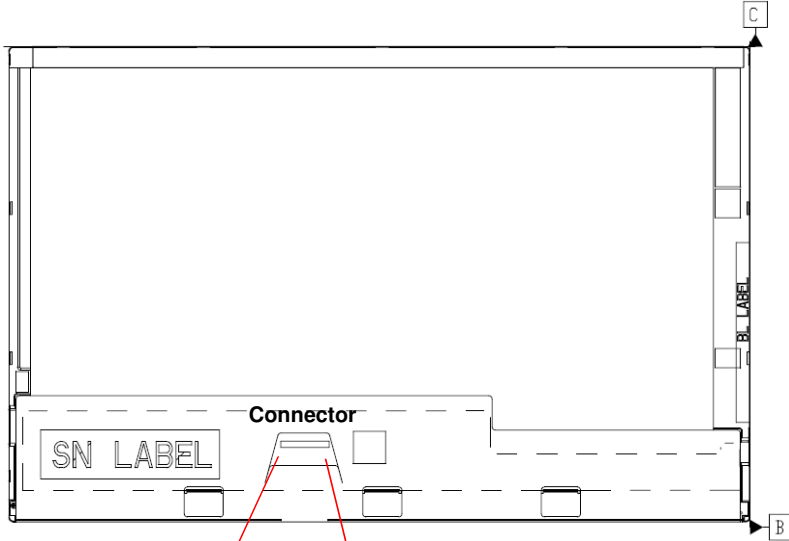

## 6.4 Interface Timing

### 6.4.1 Timing Characteristics

Basically, interface timings should match the 1440x900 /60Hz manufacturing guide line timing.

Parameter	Symbol	Min.	Typ.	Max.	Unit	
Frame Rate	-	50	60	-	Hz	
Clock frequency	$1/T_{Clock}$	-	48.2	60.2	MHz	
Vertical Section	Period	$T_V$	904	912	2048	$T_{Line}$
	Active	$T_{VD}$	900	900	900	
	Blanking	$T_{VB}$	4	12	-	
Horizontal Section	Period	$T_H$	760	880	1024	$T_{Clock}$
	Active	$T_{HD}$	720	720	720	
	Blanking	$T_{HB}$	40	160	-	

Note : DE mode only

### 6.4.2 Timing diagram

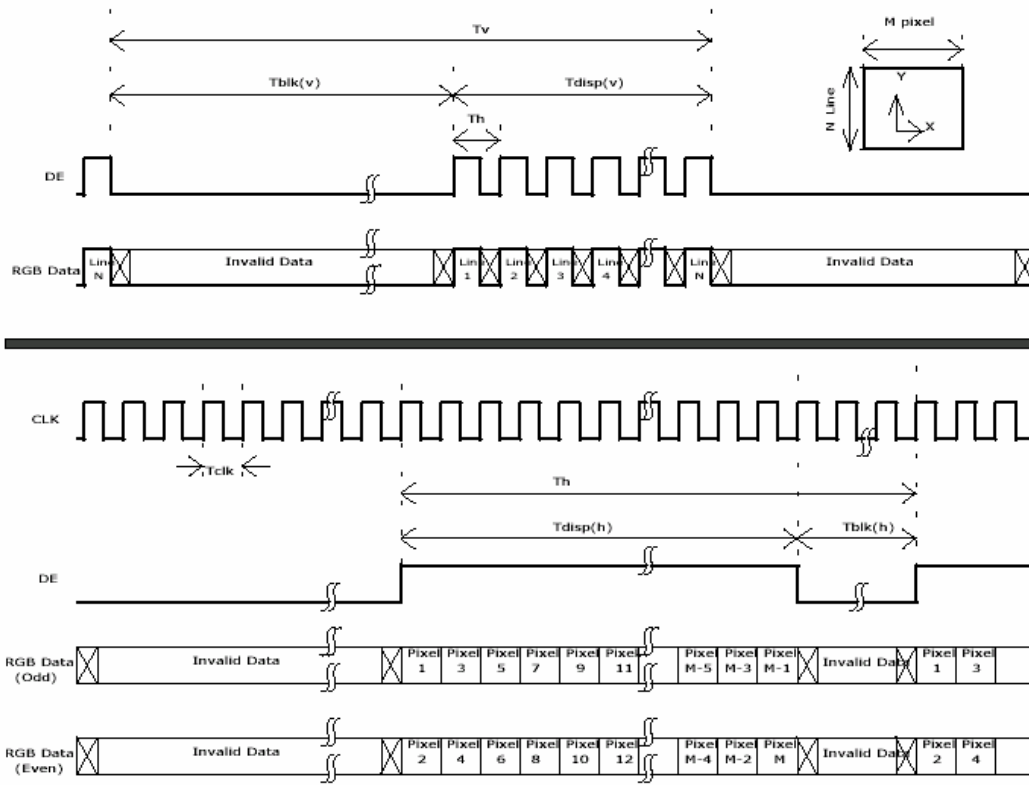

## 6.5 Power ON/OFF Sequence

VDD power and lamp on/off sequence is as follows. Interface signals are also shown in the chart. Signals from any system shall be Hi-Z state or low level when VDD is off.

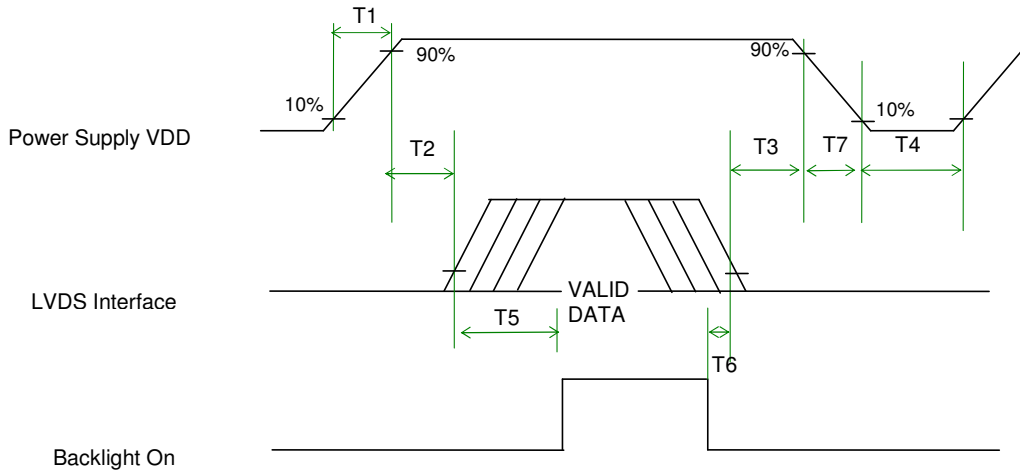

**Power Sequence Timing**

Parameter	Value			Units
	Min.	Typ.	Max.	
T1	0.5	-	10	(ms)
T2	5	-	50	(ms)
T3	0.5	-	50	(ms)
T4	400	-	-	(ms)
T5	200	-	-	(ms)
T6	200	-	-	(ms)
T7	0	-	10	(ms)



## 7. Connector Description

Physical interface is described as for the connector on module.

These connectors are capable of accommodating the following signals and will be following components.

### 7.1 TFT LCD Module

<b>Connector Name / Designation</b>	For Signal Connector
Manufacturer	JAE or compatible
Type / Part Number	JAE FI-JT40S-HF10-R3000 or compatible
Mating Housing/Part Number	JAE FI-JT40C-R3000 or compatible

## 8. Dynamic Test

### 8.1 Vibration Test

**Test condition:**

- Acceleration: 3.0 G
- Frequency: 5–150 Hz, 0.37 Oct/min with sine wave
- Sweep: 30 Minutes each Axis (X, Y, Z)

### 8.2 Shock Test Spec:

**Test condition:**

- Acceleration: 220 G , Half sine wave
- Active time: 2 ms
- Pulse: +/-X,+/-Y,+/-Z , one time for each side

**Remark:**

1. Ambient condition is  $25 \pm 5^{\circ}\text{C}$  , Relative humidity : 40% ~ 70%
2. Non-packaged and Non-operation



## 9. Reliability

Items	Required Condition	Note
Temperature Humidity Bias	Ta= 50°C, 95%RH, 300h	
High Temperature Operation	Ta= 50°C, Dry, 300h	
Low Temperature Operation	Ta= 0°C, 300h	
High Temperature Storage	Ta= 65°C, 35%RH, 300h	
Low Temperature Storage	Ta= -25°C, 50%RH, 300h	
Thermal Shock Test	Ta=-25°C to 65°C, Duration at 30 min, 100 cycles	
ESD	Contact : ±8 KV Air : ±15 KV	Note 1

**Note1:** According to EN 61000-4-2 , ESD class B: Some performance degradation allowed. No data lost  
 . Self-recoverable. No hardware failures.

**Remark:** MTBF (Excluding the LED): 30,000 hours with a confidence level 90%

## 10. Mechanical Characteristics

### 10.1 LCM Outline Dimension

註解 [BY1]:  
Get from RD-Must paste the PDF format.

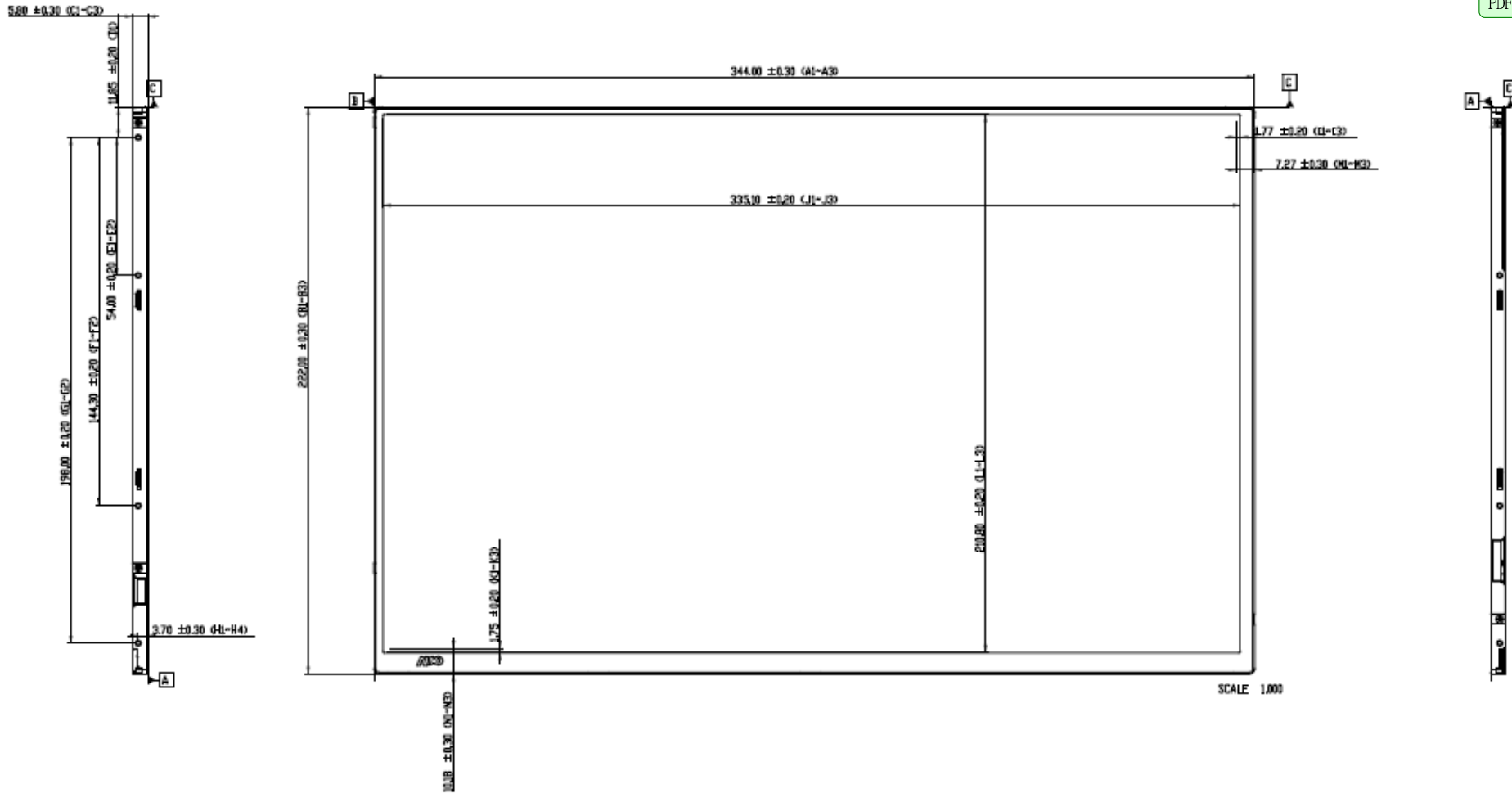

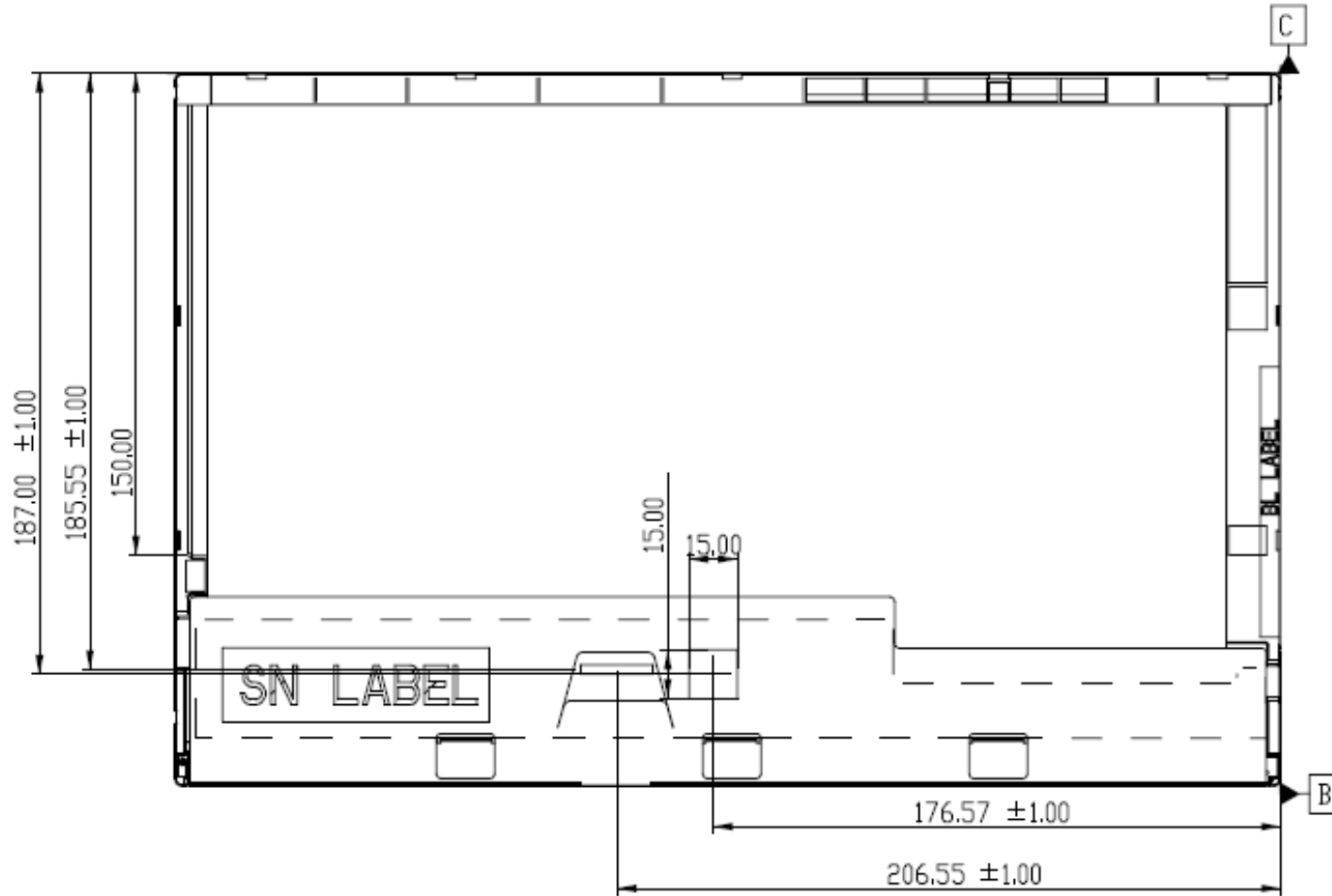

### 10.2 Screw Hole Depth and Center Position

Screw hole minimum depth, from side surface = 2.3 mm (Ref. drawing)

Screw hole center location, from front surface =  $3.7 \pm 0.2$ mm (Ref. drawing)

Screw Torque: Maximum 2.5 kgf-cm

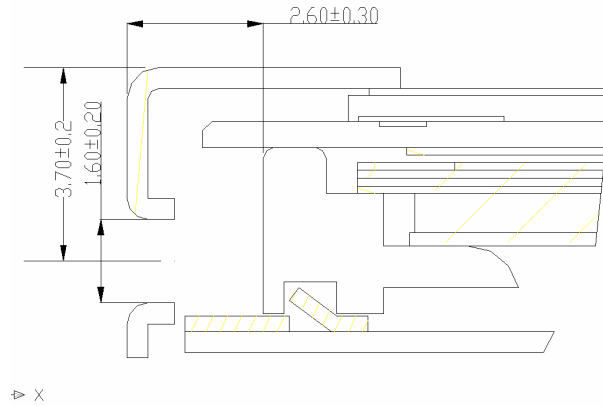

## 11. Shipping and Package

### 11.1 Shipping Label Format

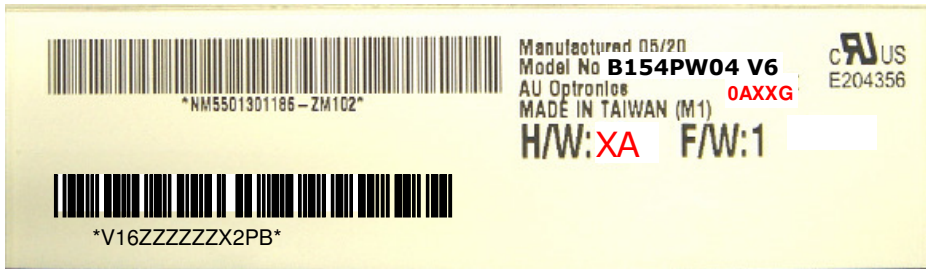

### 11.2 Carton package

The outside dimension of carton is 455 (L)mm x 380 (W)mm x 355 (H)mm

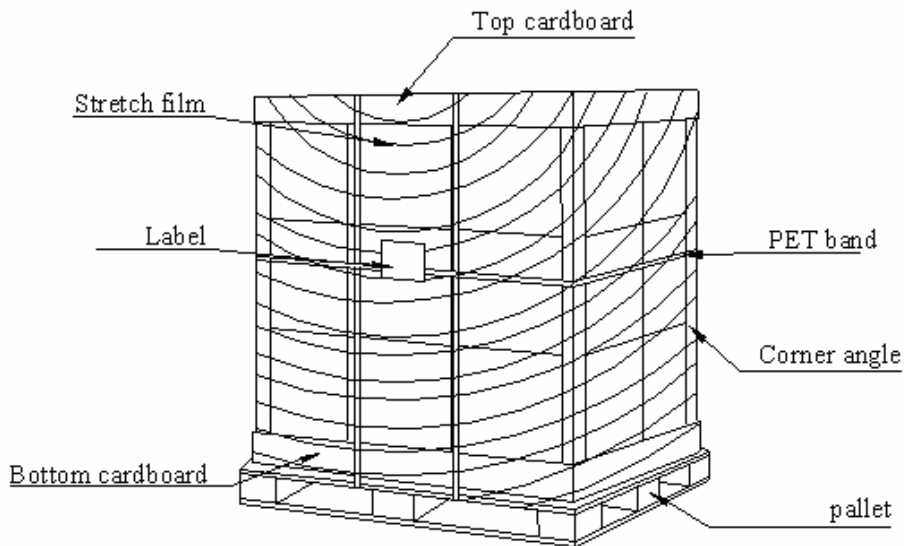
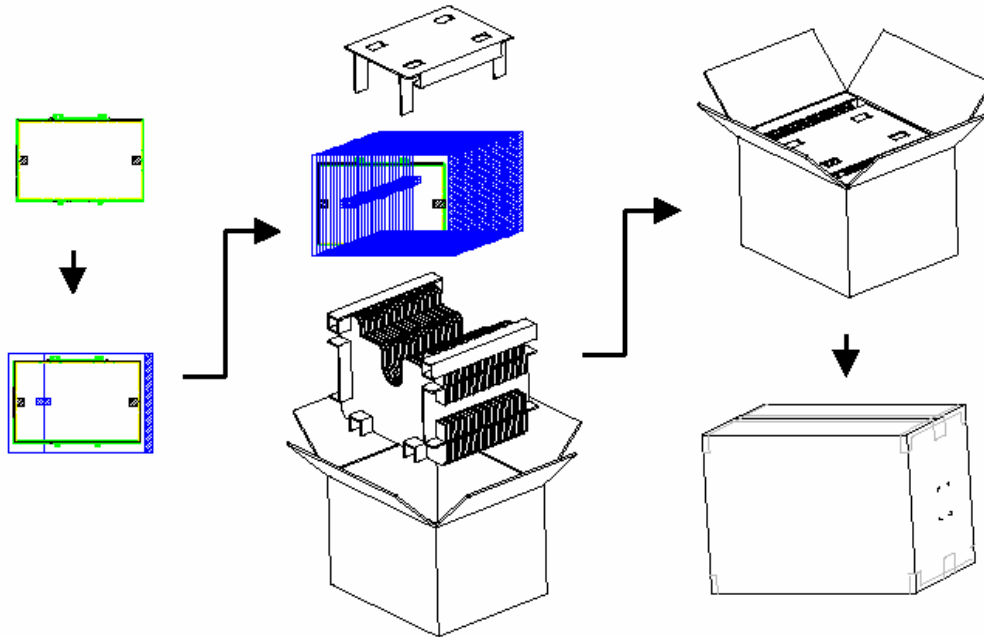

## 12. Appendix: EDID description

Address	FUNCTION	B154PW04	Value	Value	Note
HEX	Header	HEX	BIN	DEC	
00		00	00000000	0	
01		FF	11111111	255	
02		FF	11111111	255	
03		FF	11111111	255	
04		FF	11111111	255	
05		FF	11111111	255	
06		FF	11111111	255	
07		00	00000000	0	
08	EISA Manuf. Code LSB	06	00000110	6	<b>APP</b> 0 00001(A) 10000(P) 10000(P) <b>9C66</b> assign product code
09	Compressed ASCII	10	00010000	16	
0A	Product code	66	01100110	102	
0B	Product code	9C	10011100	156	
0C	32-bit ser #	01	00000001	1	unused
0D		01	00000001	1	
0E		01	00000001	1	
0F		01	00000001	1	
10	Week of manufacture	28	00101000	40	Week=40
11	Year of manufacture	10	00010000	16	Year=2006
12	EDID Structure Ver.	01	00000001	1	Digital Input  <b>33cm</b>  <b>21cm</b> <b>Gamma=2.2</b> no DPMS,Active off,RGB color
13	EDID revision #	03	00000011	3	
14	Video input definition	80	10000000	128	
15	Max H image size	21	00100001	33	
16	Max V image size	15	00010101	21	
17	Display Gamma	78	01111000	120	
18	Feature support	0A	00001010	10	
19	Red/green low bits	50	01010000	80	



# Product Specification

AU OPTRONICS CORPORATION

1A	Blue/white low bits	C5	11000101	197	
1B	Red x/ high bits	98	10011000	152	Rx=0.595
1C	Red y	58	01011000	88	Ry=0.345
1D	Green x	52	01010010	82	Gx=0.32
1E	Green y	8E	10001110	142	Gy=0.555
1F	Blue x	27	00100111	39	Bx=0.155
20	Blue y	25	00100101	37	By=0.145
21	White x	50	01010000	80	Wx=0.313
22	White y	54	01010100	84	Wy=0.329
23	Established timing 1	00	00000000	0	unused
24	Established timing 2	00	00000000	0	-
25	Manufacturer's Timing	00	00000000	0	
26	Standard timing #1	01	00000001	1	unused
27	Standard timing #1	01	00000001	1	
28	Standard timing #2	01	00000001	1	
29	Standard timing #2	01	00000001	1	
2A	Standard timing #3	01	00000001	1	
2B	Standard timing #3	01	00000001	1	
2C	Standard timing #4	01	00000001	1	
2D	Standard timing #4	01	00000001	1	
2E	Standard timing #5	01	00000001	1	
2F	Standard timing #5	01	00000001	1	
30	Standard timing #6	01	00000001	1	
31	Standard timing #6	01	00000001	1	
32	Standard timing #7	01	00000001	1	
33	Standard timing #7	01	00000001	1	
34	Standard timing #8	01	00000001	1	
35	Standard timing #8	01	00000001	1	





# Product Specification

AU OPTRONICS CORPORATION

36	Pixel Clock/10,000 (LSB)	9E	10011110	158	Timing Descriptor #1
37	Pixel Clock/10,000 (MSB)	25	00100101	37	
38	Horiz. Active pixels(Lower 8 bits)	A0	10100000	160	Horiz active=1440 pixels
39	Horiz.Blanking (Lower 8 bits)	40	01000000	64	Horiz blanking=320 pixels
3A	Horiz. Active pixels:Horiz. Blanking (Upper4:4 bits)	51	01010001	81	Vertcal active=900 lines
3B		84	10000100	132	
3C		0C	00001100	12	
3D	Vert. Active pixels:Vert. Blanking (Upper4:4 bits)	30	00110000	48	Horiz sync. Offset= 64 pixels
3E		40	01000000	64	
3F		20	00100000	32	
40	Vert. Sync. Offset=xx lines, Sync Width=xx lines	33	00110011	51	Verti sync. Offset= 3 lines, Sync Width=3 lines
41	Horz. Ver. Sync/Width (upper 2 bits)	00	00000000	0	
42	Hori. Image size (Lower 8 bits)	4C	01001100	76	Hori image size= 332 mm
43	Vert. Image size (Lower 8 bits)	CF	11001111	207	Verti image size= 207 mm
44	Hori. Image size : Vert. Image size (Upper 4 bits)	10	00010000	16	



# Product Specification

AU OPTRONICS CORPORATION

45		00	00000000	0	<b>Horizontal Border = 0</b> <b>Vertical Border = 0</b>	
46		00	00000000	0		
47		18	00011000	24		
48	<b>Detailed timing/monitor descriptor #2</b>	00	00000000	0		
49		00	00000000	0		
4A		00	00000000	0		
4B	<b>Version edid signature edid signature</b>	01	00000001	1	<b>For</b>	
4C		00	00000000	0	<b>For</b>	
4D		06	00000110	6	<b>For</b>	
4E		10	00010000	16	<b>For</b>	
4F		<b>Link Type (LVDS Link,MSB justified)</b>	30	00110000	48	<b>For</b>
50	<b>Pixel and link component format (6-bit panel interface)</b>	00	00000000	0	<b>For</b>	
51	<b>Panel features (No inverter)</b>	00	00000000	0	<b>For</b>	
52		00	00000000	0	<b>ASCII Data String: B154PW04 V0</b>	
53		00	00000000	0		
54		00	00000000	0		
55		00	00000000	0		
56		00	00000000	0		
57		00	00000000	0		
58		0A	00001010	10		
59		20	00100000	32		
5A		<b>Detailed timing/monitor descriptor #3</b>	00	00000000		0
5B			00	00000000		0
5C	00		00000000	0		
5D	FE		11111110	254		
5E	00		00000000	0		
5F		42	01000010	66	<b>B</b>	
60		31	00110001	49	<b>1</b>	
61		35	00110101	53	<b>5</b>	
62		34	00110100	52	<b>4</b>	
63		50	01010000	80	<b>P</b>	



# Product Specification

AU OPTRONICS CORPORATION

64		57	01010111	87	<b>W 0 4  V 0</b>
65		30	00110000	48	
66		34	00110100	52	
67		20	00100000	32	
68		56	01010110	86	
69		30	00110000	48	
6A		0A	00001010	10	
6B		20	00100000	32	
6C	<b>Detailed timing/monitor descriptor #4</b>	00	00000000	0	
6D		00	00000000	0	
6E		00	00000000	0	
6F		FE	11111110	254	
70		00	00000000	0	
71		43	01000011	67	<b>C o l o r  L C D</b>
72		6F	01101111	111	
73		6C	01101100	108	
74		6F	01101111	111	
75		72	01110010	114	
76		20	00100000	32	
77		4C	01001100	76	
78		43	01000011	67	
79		44	01000100	68	
7A		0A	00001010	10	
7B		20	00100000	32	
7C		20	00100000	32	
7D		20	00100000	32	
7E	<b>Extension Flag</b>	00	00000000	0	
7F	<b>Checksum</b>	87	10000111	135	