



Product Specification

AU OPTRONICS CORPORATION

Preliminary Specifications

Final Specifications

Module	12.1" WXGA Color TFT-LCD
Model Name	B121EW03 V7 (HW 0A/1A)



Product Specification

AU OPTRONICS CORPORATION

Customer	Date
Checked & Approved by	Date
<p>Note: This Specification is subject to change without notice.</p>	

Approved by	Date
Prepared by	Date
<p>NBBU Marketing Division / AU Optronics corporation</p>	

Contents

1. Handling Precautions	5
2. General Description	6
2.1 General Specification	6
2.2 Optical Characteristics	7
3. Functional Block Diagram	12
4. Absolute Maximum Ratings	13
4.1 Absolute Ratings of TFT LCD Module.....	13
4.2 Absolute Ratings of Backlight Unit	13
4.3 Absolute Ratings of Environment	13
5. Electrical characteristics	14
5.1 TFT LCD Module.....	14
5.2 Backlight Unit.....	16



Product Specification

AU OPTRONICS CORPORATION

6. Signal Characteristic	18
6.1 Pixel Format Image.....	18
6.2 The input data format.....	19
6.3 Signal Description/Pin Assignment	20
6.4 Interface Timing.....	23
7. Connector Description	26
7.1 TFT LCD Module.....	26
7.2 Backlight Unit.....	26
7.3 Signal for Lamp connector.....	26
8. Dynamic Test	27
8.1 Vibration Test	27
8.2 Shock Test Spec:	27
9. Reliability	28
10. Mechanical Characteristics	29
10.1 LCM Outline Dimension	29
10.2 Screw Hole Depth and Center Position	32
11. Shipping and Package	33
11.1 Shipping Label Format	33
11.2 Carton package	34
11.3 Shipping package of palletizing sequence	34
12. Appendix: EDID description	35



Product Specification

AU OPTRONICS CORPORATION

Record of Revision

Version and Date	Page	Old description	New Description	Remark
0.1 2007/9/17	All	First Edition		



1. Handling Precautions

- 1) Since front polarizer is easily damaged, pay attention not to scratch it.
- 2) Be sure to turn off power supply when inserting or disconnecting from input connector.
- 3) Wipe off water drop immediately. Long contact with water may cause discoloration or spots.
- 4) When the panel surface is soiled, wipe it with absorbent cotton or other soft cloth.
- 5) Since the panel is made of glass, it may break or crack if dropped or bumped on hard surface.
- 6) Since CMOS LSI is used in this module, take care of static electricity and insure human earth when handling.
- 7) Do not open nor modify the Module Assembly.
- 8) Do not press the reflector sheet at the back of the module to any directions.
- 9) In case if a Module has to be put back into the packing container slot after once it was taken out from the container, do not press the center of the CCFL Reflector edge. Instead, press at the far ends of the CCFL Reflector edge softly. Otherwise the TFT Module may be damaged.
- 10) At the insertion or removal of the Signal Interface Connector, be sure not to rotate nor tilt the Interface Connector of the TFT Module.
- 11) After installation of the TFT Module into an enclosure (Notebook PC Bezel, for example), do not twist nor bend the TFT Module even momentary. At designing the enclosure, it should be taken into consideration that no bending/twisting forces are applied to the TFT Module from outside. Otherwise the TFT Module may be damaged.
- 12) Cold cathode fluorescent lamp (CCFL) in LCD contains a small amount of mercury. Please follow local ordinances or regulations for disposal.
- 13) Small amount of materials having no flammability grade is used in the LCD module. The LCD module should be supplied by power complied with requirements of Limited Power Source (IEC60950 or UL1950), or be applied exemption.
- 14) The LCD module is designed so that the CCFL in it is supplied by Limited Current Circuit (IEC60950 or UL1950). Do not connect the CCFL in Hazardous Voltage Circuit.



Product Specification

AU OPTRONICS CORPORATION

2. General Description

B121EW03 V7 is a Color Active Matrix Liquid Crystal Display composed of a TFT LCD panel, a driver circuit, and backlight system. The screen format is intended to support the WXGA (1280(H) x 800(V)) screen and 262k colors (RGB 6-bits data driver) without backlight inverter. All input signals are LVDS interface compatible.

B121EW03 V7 is designed for a display unit of notebook style personal computer and industrial machine.

2.1 General Specification

The following items are characteristics summary on the table at 25 °C condition:

Items	Unit	Specifications			
Screen Diagonal	[mm]	307.9 (12.1W")			
Active Area	[mm]	261.1 X 163.2			
Pixels H x V		1280x3(RGB) x 800			
Pixel Pitch	[mm]	0.204X0.204			
Pixel Format		R.G.B. Vertical Stripe			
Display Mode		Normally White			
White Luminance (I_{CCFL}=6.0mA) Note: I _{CCFL} is lamp current	[cd/m ²]	220 typ. (5 points average) 187 min. (5 points average) (Note1)			
Luminance Uniformity		1.25 max. (5 points)			
Contrast Ratio		400 typ			
Response Time	[ms]	16 typ / 25 Max			
Nominal Input Voltage VDD	[Volt]	+3.3 typ.			
Power Consumption	[Watt]	4.5 max.			
Weight	[Grams]	290 max.			
Physical Size	[mm]		L	W	T
		Max	276.32	178.5	5.5
		Typical	275.82	178.0	-
	Min	275.32	177.5	-	
Electrical Interface		1 channel LVDS			
Surface Treatment		Glare, Hardness 3H, Reflection 4.3%			



Product Specification

AU OPTRONICS CORPORATION

Support Color		262K colors (RGB 6-bit)
Temperature Range Operating Storage (Non-Operating)	[°C] [°C]	0 to +50 -20 to +60
RoHS Compliance		RoHS Compliance

2.2 Optical Characteristics

The optical characteristics are measured under stable conditions at 25°C (Room Temperature) :

Item	Unit	Conditions	Min.	Typ.	Max.	Note
White Luminance I _{CCFL} =6.0mA	[cd/m ²]	5 points average	187	220	-	1, 4, 5.
Viewing Angle	[degree] [degree]	Horizontal (Right) CR = 10 (Left)	- -	40 40	- -	8
	[degree] [degree]	Vertical (Upper) CR = 10 (Lower)	- -	20 40	- -	
Luminance Uniformity		5 Points	-	-	1.25	1
CR: Contrast Ratio			300	400	-	6
Cross talk	%				4	7
Response Time	[msec]	Rising	-	-	-	8
	[msec]	Falling	-	-	-	
Chromaticity of color Coordinates (CIE 1931) NTSC	[msec]	Rising + Falling	-	16	25	2,8
	%	Red x	0.560	0.580	0.600	
		Red y	0.320	0.340	0.360	
		Green x	0.290	0.310	0.330	
		Green y	0.530	0.550	0.570	
		Blue x	0.135	0.155	0.175	
		Blue y	0.135	0.155	0.175	
		White x	0.283	0.313	0.343	
		White y	0.299	0.329	0.359	
		CIE 1931	-	45	-	

Note 1: 5 points position (Ref: Active area)

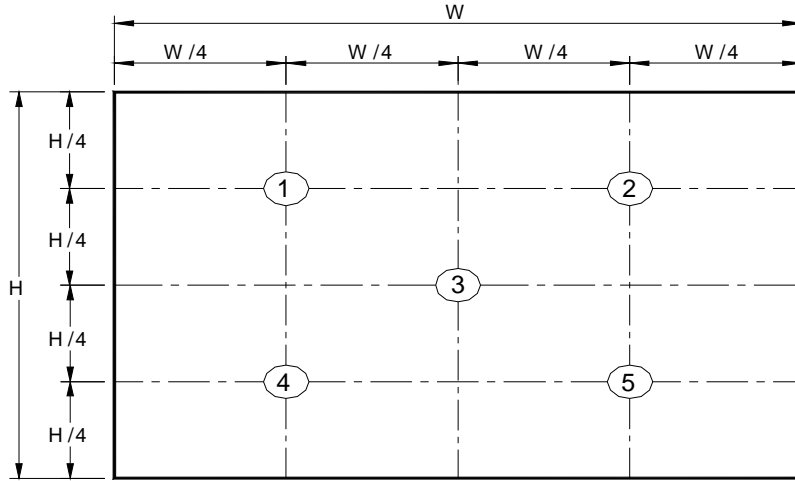

Note 2: 13 points position (Ref: Active area)

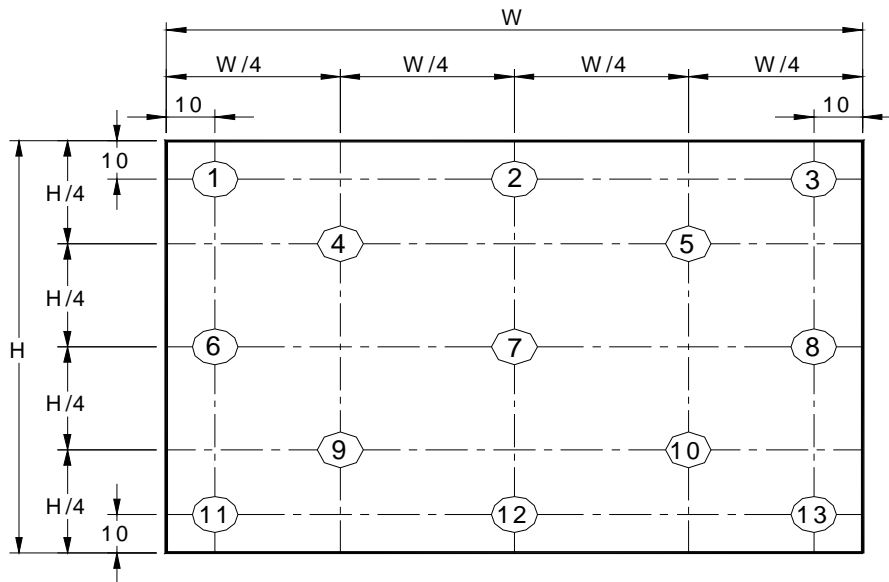

Note 3: The luminance uniformity of 5 or 13 points is defined by dividing the maximum luminance values by the minimum test point luminance

$$\delta_{w5} = \frac{\text{Maximum Brightness of five points}}{\text{Minimum Brightness of five points}}$$

$$\delta_{w13} = \frac{\text{Maximum Brightness of thirteen points}}{\text{Minimum Brightness of thirteen points}}$$

Note 4: Measurement method

The LCD module should be stabilized at given temperature for 30 minutes to avoid abrupt temperature change during measuring. In order to stabilize the luminance, the measurement should be executed after lighting Backlight for 30 minutes in a stable, windless and dark room.

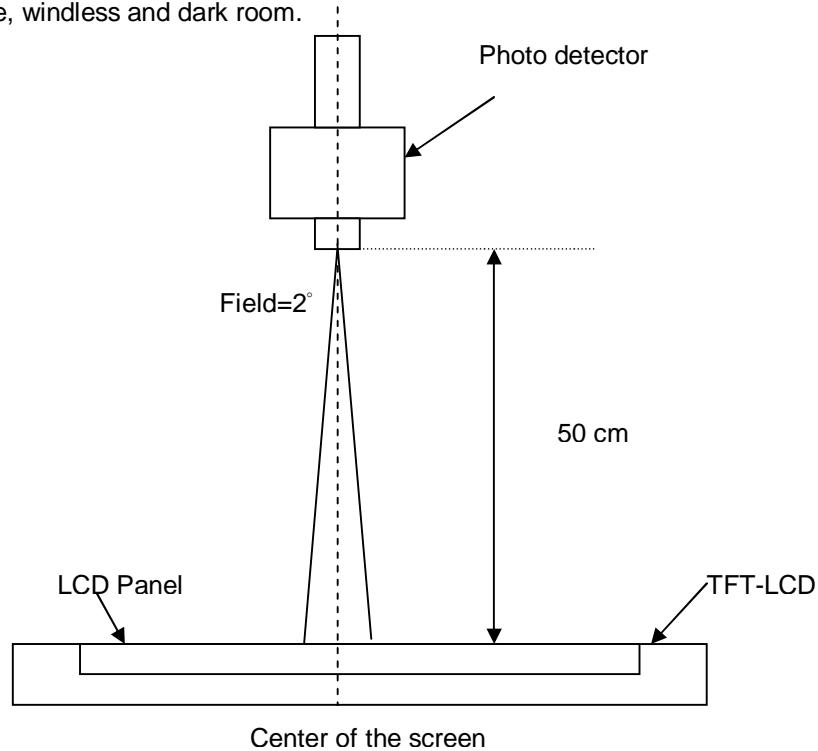

Note 5 : Definition of Average Luminance of White (Y_L):

Measure the luminance of gray level 63 at 5 points , $Y_L = [L(1) + L(2) + L(3) + L(4) + L(5)] / 5$

$L(x)$ is corresponding to the luminance of the point X at Figure in Note (1).

Note 6 : Definition of contrast ratio:

Contrast ratio is calculated with the following formula.

$$\text{Contrast ratio (CR)} = \frac{\text{Brightness on the "White" state}}{\text{Brightness on the "Black" state}}$$

Note 7 : Definition of Cross Talk (CT)

$$CT = |Y_B - Y_A| / Y_A \times 100 (\%)$$

Where

Y_A = Luminance of measured location without gray level 0 pattern (cd/m^2)



Product Specification

AU OPTRONICS CORPORATION

Y_B = Luminance of measured location with gray level 0 pattern (cd/m^2)

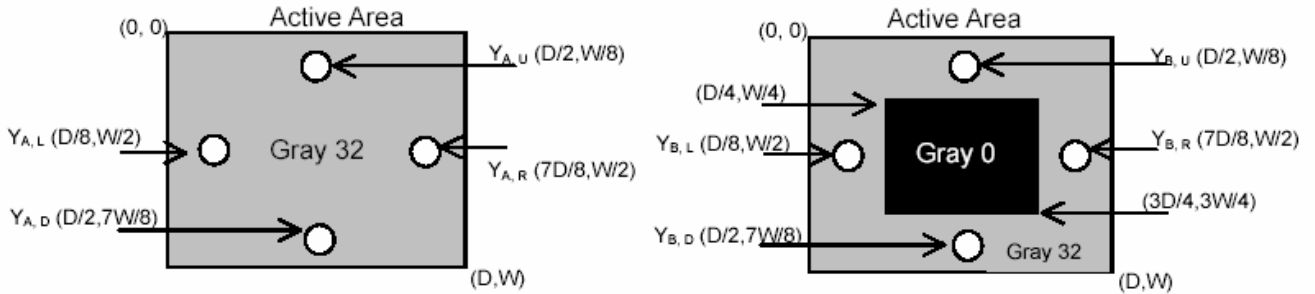

Note 8: Definition of response time:

The output signals of BM-7 or equivalent are measured when the input signals are changed from "Black" to "White" (falling time) and from "White" to "Black" (rising time), respectively. The response time interval between the 10% and 90% of amplitudes. Refer to figure as below.

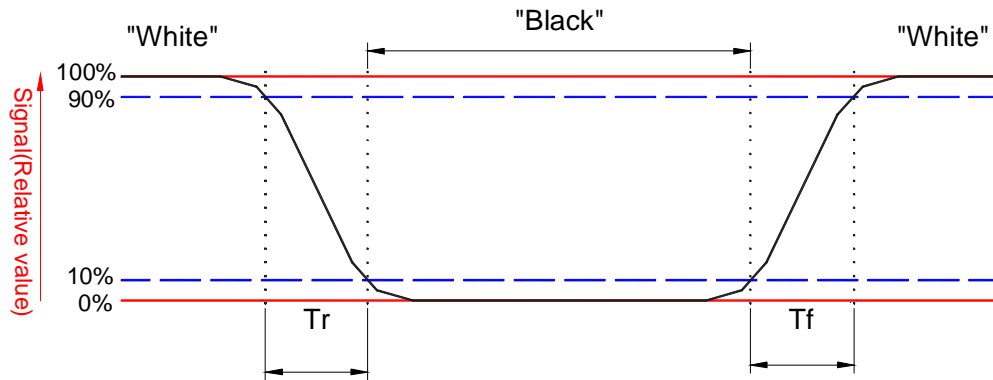

Note 8. Definition of viewing angle

Viewing angle is the measurement of contrast ratio ≥ 10 , at the screen center, over a 180° horizontal and 180° vertical range (off-normal viewing angles). The 180° viewing angle range is broken down as follows; 90° (θ) horizontal left and right and 90° (Φ) vertical, high (up) and low (down). The measurement direction is typically perpendicular to the display surface with the screen rotated about its center to develop the desired measurement viewing angle.

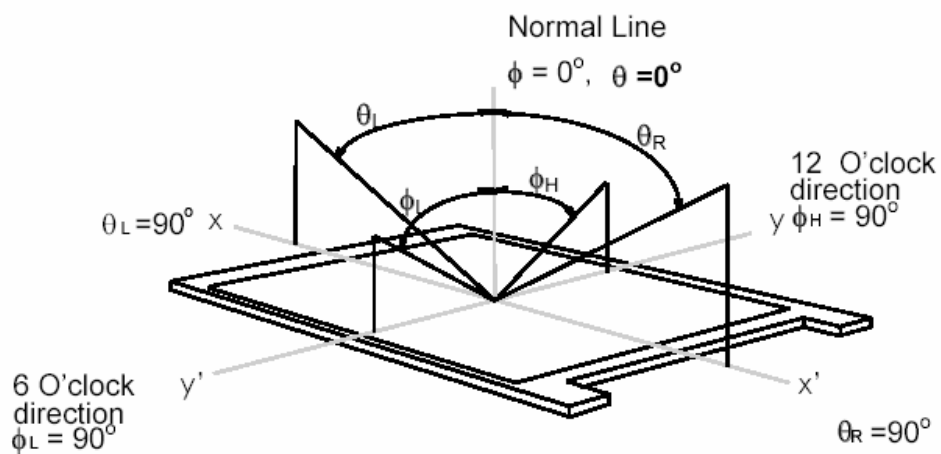

3. Functional Block Diagram

The following diagram shows the functional block of the 12.1 inches wide Color TFT/LCD Module:

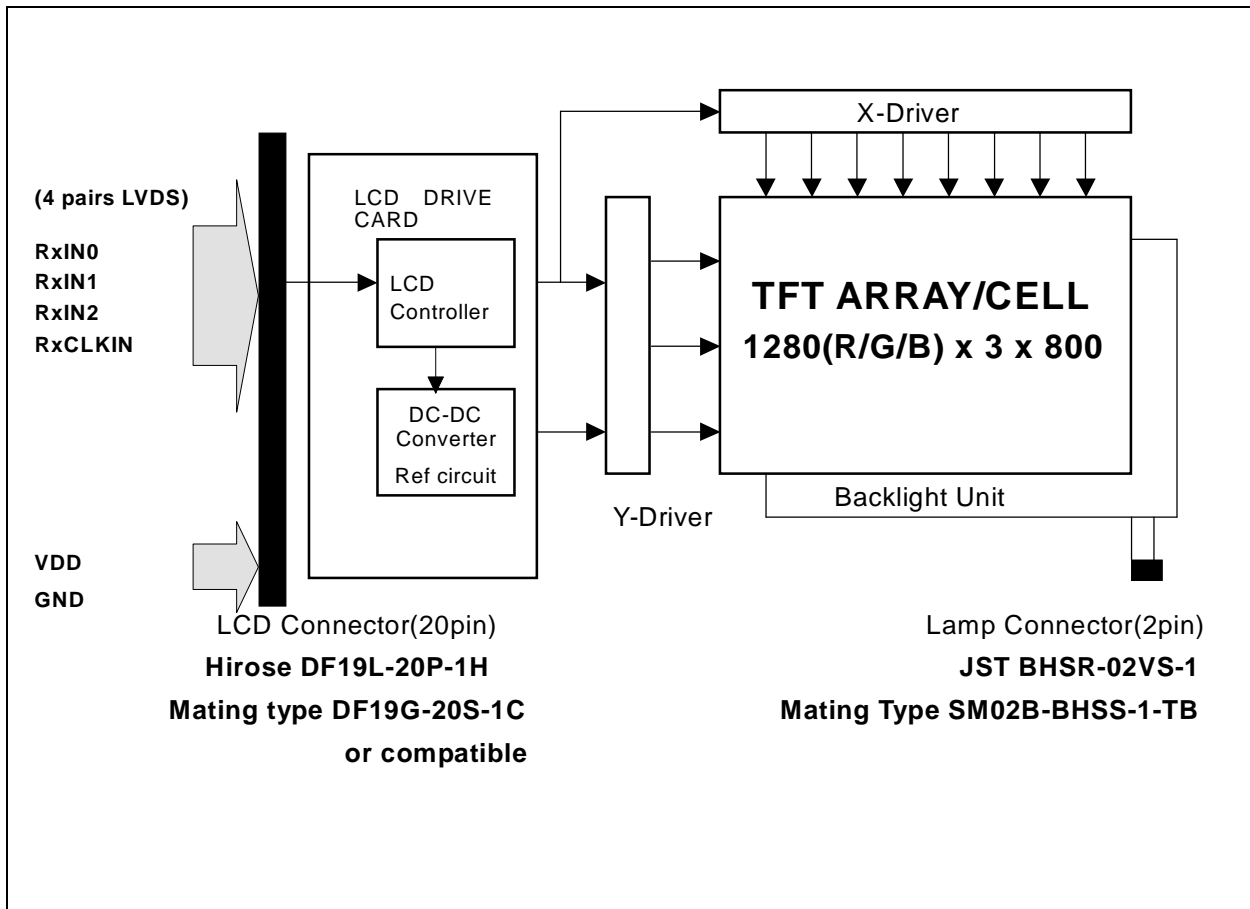

4. Absolute Maximum Ratings

An absolute maximum rating of the module is as following:

4.1 Absolute Ratings of TFT LCD Module

Item	Symbol	Min	Max	Unit	Conditions
Logic/LCD Drive	Vin	-0.3	+4.0	[Volt]	Note 1,2

4.2 Absolute Ratings of Backlight Unit

Item	Symbol	Min	Max	Unit	Conditions
CCFL Current	ICCFL	3.0	7.0	[mA] rms	Note 1,2

4.3 Absolute Ratings of Environment

Item	Symbol	Min	Max	Unit	Conditions
Operating Temperature	TOP	0	+50	[°C]	Note 3
Operation Humidity	HOP	5	95	[%RH]	Note 3
Storage Temperature	TST	-20	+60	[°C]	Note 3
Storage Humidity	HST	5	95	[%RH]	Note 3

Note 1: At Ta (25°C)

Note 2: Permanent damage to the device may occur if exceed maximum values

Note 3: For quality performance, please refer to AUO IIS (Incoming Inspection Standard).

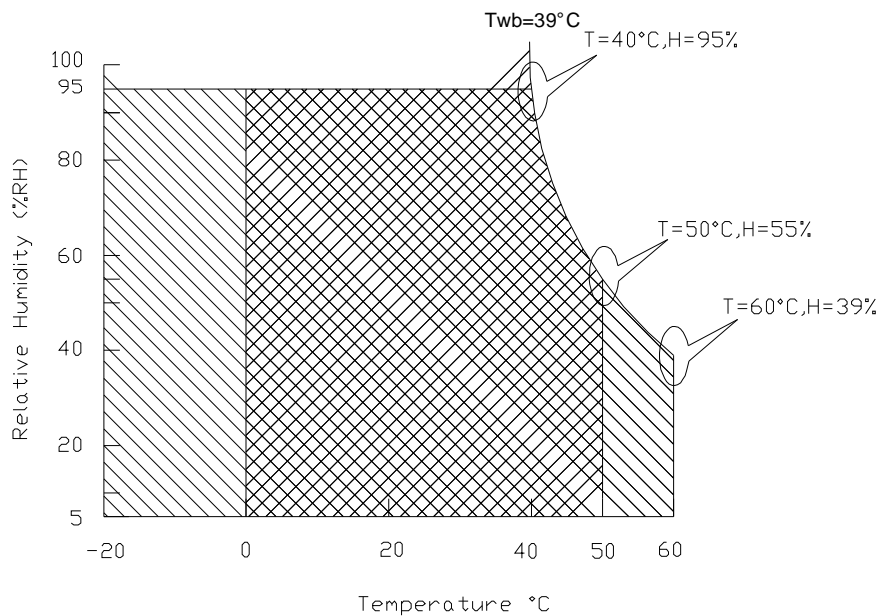

Operating Range 

Storage Range

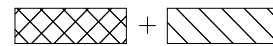

5. Electrical characteristics

5.1 TFT LCD Module

5.1.1 Power Specification

Input power specifications are as follows;

Symble	Parameter	Min	Typ	Max	Units	Note
VDD	Logic/LCD Drive Voltage	3.0	3.3	3.6	[Volt]	
PDD	VDD Power	-	-	0.8	[Watt]	Note 1/2
IDD	IDD Current	-	222	242	[mA]	Note 1/2
IRush	Inrush Current	-	-	2000	[mA]	Note 3
VDDrp	Allowable Logic/LCD Drive Ripple Voltage	-	-	100	[mV] p-p	

Note 1 : Maximum Measurement Condition : Black Pattern

Note 2 : Typical Measurement Condition: Mosaic Pattern

Note 3 : Measure Condition

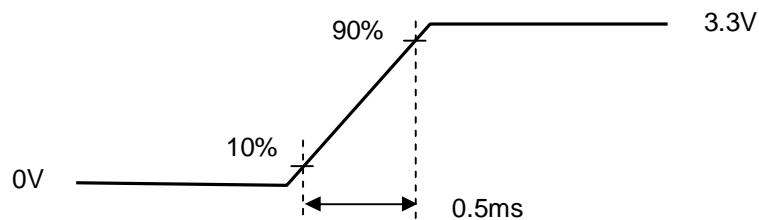
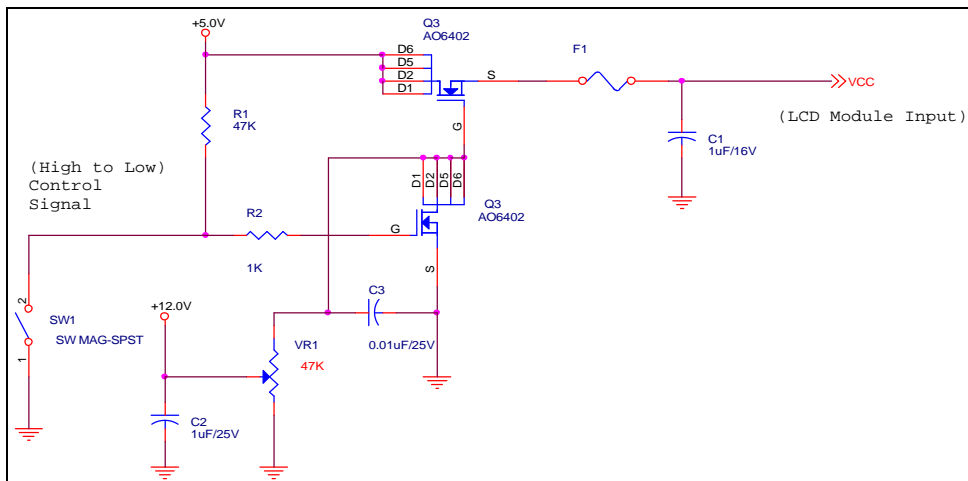

Vin rising time

5.1.2 Signal Electrical Characteristics

Input signals shall be low or High-impedance state when VDD is off.

It is recommended to refer the specifications of THC63LVDF84A (Thine Electronics Inc.) in detail.

Signal electrical characteristics are as follows;

Parameter	Condition	Min	Max	Unit
Vth	Differential Input High Threshold (Vcm=+1.2V)	-	100	[mV]
Vtl	Differential Input Low Threshold (Vcm=+1.2V)	-100	-	[mV]
Vcm	Differential Input Common Mode Voltage	0.4	VCC-1.1	[V]

Note: LVDS Signal Waveform

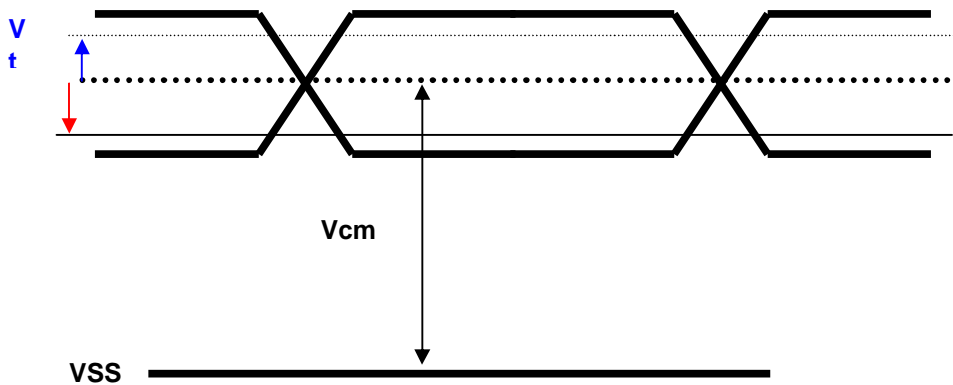



5.2 Backlight Unit

CCFL Parameter guideline for CCFL Inverter selection (Ref. Remark 1)

Parameter	Min	Typ	Max	Units	Condition
CCFL current(I_{CCFL})	2.0	6.0	7.0	[mA] rms	($T_a=25^{\circ}C$) Note 1
CCFL Frequency(F_{CCFL})	45	62	70	[KHz]	($T_a=25^{\circ}C$) Note 2,3
CCFL startup Voltage(V_s)			1750	[Volt] rms	($T_a= 0^{\circ}C$) Note 4
CCFL startup Voltage(V_s)			1460	[Volt] rms	($T_a= 25^{\circ}C$) Note 4
CCFL Voltage (Reference) (V_{CCFL})	522	580	638	[Volt] rms	($T_a=25^{\circ}C$) Note 5
CCFL Power consumption (P_{CCFL})	-	3.5	4.5	[Watt]	($T_a=25^{\circ}C$) Note 5
CCFL Life-Time	12,000	-	-	Hour	($T_a=25^{\circ}C$) Note 7

To optimun TFT LCD performance, the LAMP inverter PWM Frequesncy define as:210 +/-5 Hz

Remark 1: Typ are AUO recommended Design Points.

- 1-1 All of characteristics listed are measured under the condition using the AUO Test inverter.
- 1-2 In case of using an inverter other than listed, it is recommended to check the inverter carefully.
Sometimes, interfering noise stripes appear on the screen, and substandard luminance or flicker at low power may happen.
- 1-3 In designing an inverter, it is suggested to check safety circuit very carefully. Impedance of CCFL, for instance, becomes more than 1 [M ohm] when CCFL is damaged.
- 1-4 Generally, CCFL has some amount of delay time after applying starting voltage. It is recommended to keep on applying starting voltage for **1 [Sec]** until discharge.
- 1-5 CCFL discharge frequency must be carefully chosen so as not to produce interfering noise stripes on the screen.
- 1-6 Reducing CCFL current increases CCFL discharge voltage and generally increases CCFL discharge frequency. So all the parameters of an inverter should be carefully designed so as not to produce too much leakage current from high-voltage output of the inverter.

Note 1: It should be employed the inverter which has “Duty Dimming”, if ICCFL is less than 4mA.

Note 2: CCFL discharge frequency should be carefully determined to avoid interference between inverter and TFT LCD.

Note 3: The frequency range will not affect to lamp life and reliability characteristics.

Note 4: **The output voltage of inverter should be able to give out a power after ballast capacitor , the generating capacity have to be larger than a lamp startup voltage**, otherwise backlight may has blinking for a moment after turns on or can not be turned on.

Note 5: Calculator value for reference ($I_{CCFL} \times V_{CCFL} = P_{CCFL}$)

Note 6: Requirements for a system inverter design, which is intended to have a better display performance, a better power efficiency and a more reliable lamp, are following.

It shall help increase the lamp lifetime and reduce leakage current.

- a. The asymmetry rate of the inverter waveform should be less than 10%.
- b. The distortion rate of the waveform should be within $\sqrt{2} \pm 10\%$.

* Inverter output waveform had better be more similar to ideal sine wave.

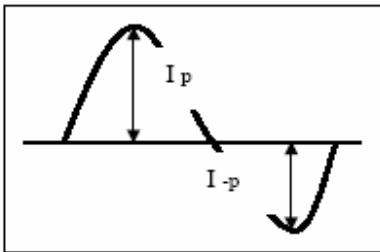

* Asymmetry rate:

$$\frac{|I_p - I_{-p}|}{I_{rms}} * 100\%$$

* Distortion rate

$$I_p \text{ (or } I_{-p}) / I_{rms}$$

Note 7: It is an edge-type BLU with single CCFL, the life-time define as the brightness decay to 50% of original value and under normal operation.

6. Signal Characteristic

6.1 Pixel Format Image

Following figure shows the relationship of the input signals and LCD pixel format.

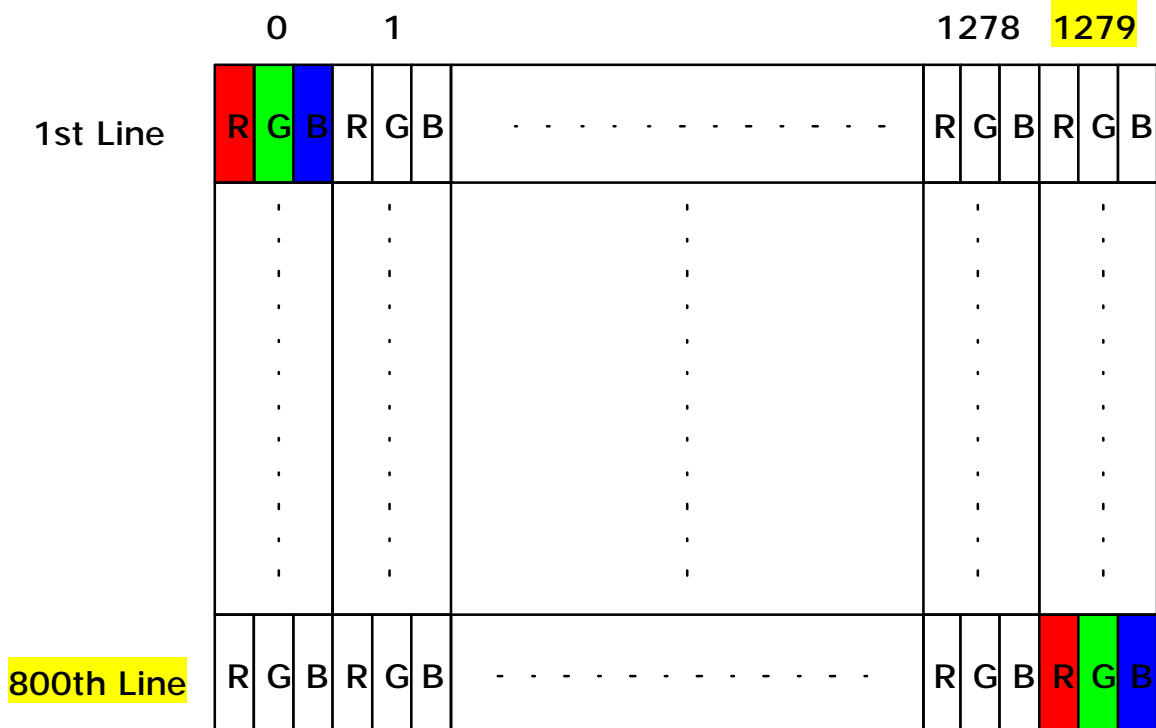

6.2 The input data format

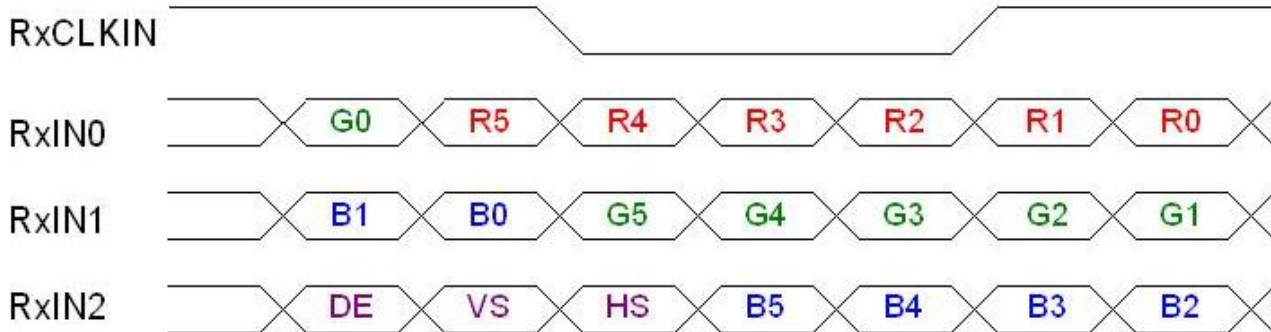

Signal Name	Description	
R5 R4 R3 R2 R1 R0	Red Data 5 (MSB) Red Data 4 Red Data 3 Red Data 2 Red Data 1 Red Data 0 (LSB)	Red-pixel Data Each red pixel's brightness data consists of these 6 bits pixel data.
G5 G4 G3 G2 G1 G0	Green Data 5 (MSB) Green Data 4 Green Data 3 Green Data 2 Green Data 1 Green Data 0 (LSB)	Green-pixel Data Each green pixel's brightness data consists of these 6 bits pixel data.
B5 B4 B3 B2 B1 B0	Blue Data 5 (MSB) Blue Data 4 Blue Data 3 Blue Data 2 Blue Data 1 Blue Data 0 (LSB)	Blue-pixel Data Each blue pixel's brightness data consists of these 6 bits pixel data.
RxCLKIN	Data Clock	The typical frequency is 71.1 MHz. The signal is used to strobe the pixel data and DE signals. All pixel data shall be valid at the falling edge when the DE signal is high.
DE	Display Timing	This signal is strobed at the falling edge of RxCLKIN. When the signal is high, the pixel data shall be valid to be displayed.
VS	Vertical Sync	The signal is synchronized to RxCLKIN .
HS	Horizontal Sync	The signal is synchronized to RxCLKIN .

Note: Output signals from any system shall be low or High-impedance state when VDD is off.



6.3 Signal Description/Pin Assignment

LVDS is a differential signal technology for LCD interface and high speed data transfer device.

Pin#	Signal Name	Pin#	Signal Name
1	GND	2	VDD
3	VDD	4	VDD _{EDID}
5	AGING	6	CLK _{EDID}
7	DATA _{EDID}	8	RxIN0N
9	RxIN0P	10	GND
11	RxIN1N	12	RxIN1P
13	GND	14	RxIN2N
15	RxIN2P	16	GND
17	RxCLKINN	18	RxCLKINP
19	GND	20	GND

Note1: Start from right side

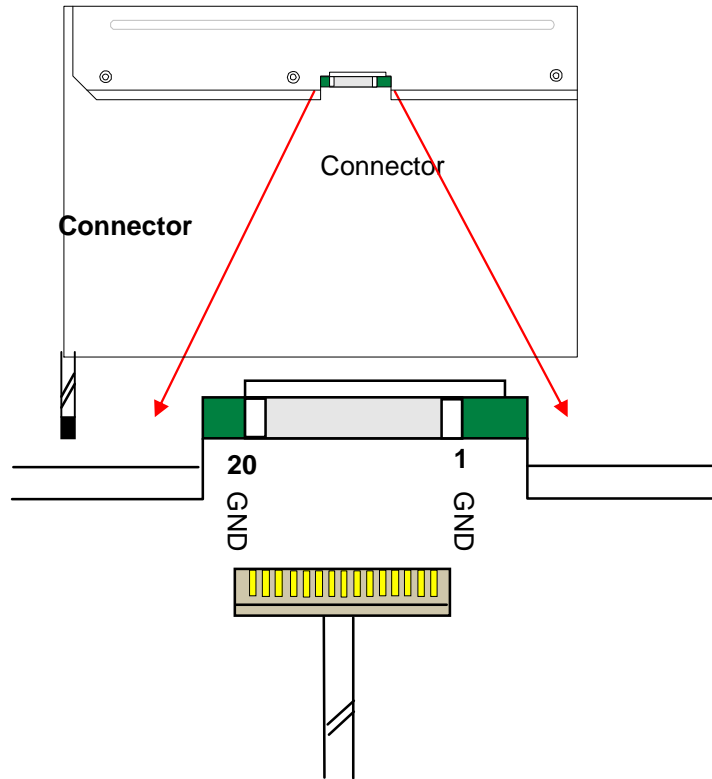

Note2: Input signals shall be low or High-impedance state when VDD is off.

internal circuit of LVDS inputs are as following.

The module uses a 100ohm resistor between positive and negative data lines of each receiver input

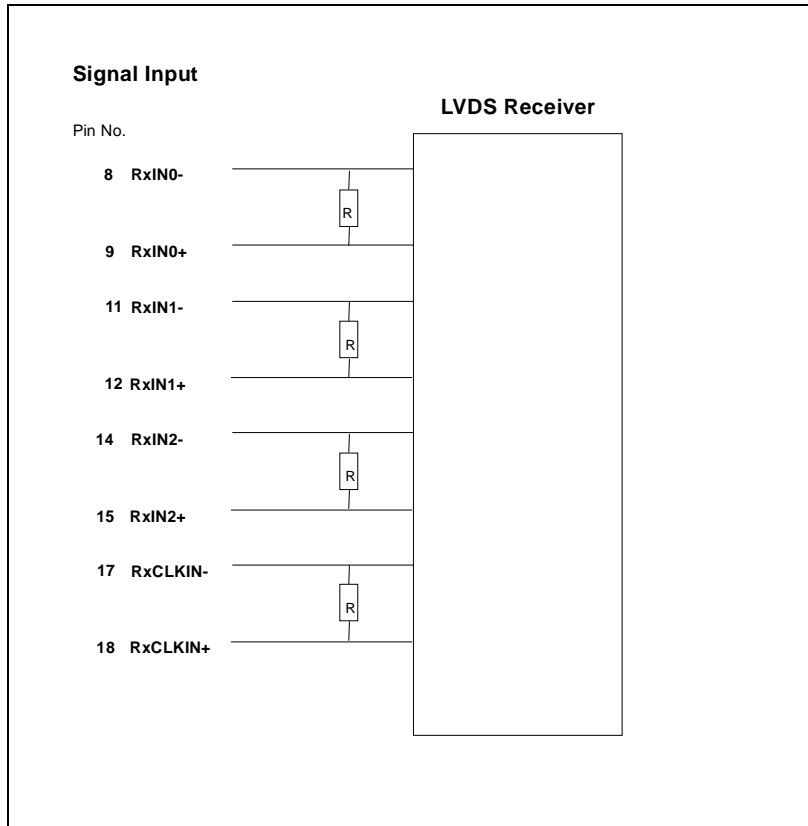

6.4 Interface Timing

6.4.1 Timing Characteristics

Basically, interface timings should match the 1280x800 /60Hz manufacturing guide line timing.

Parameter	Symbol	Min.	Typ.	Max.	Unit	
Frame Rate	-	-	60	-	Hz	
Clock frequency	$1/T_{\text{Clock}}$	-	71.1	-	MHz	
Vertical Section	Period	T_V	-	823	-	T_{Line}
	Active	T_{VD}	-	800	-	
	Blanking	T_{VB}	-	23	-	
Horizontal Section	Period	T_H	-	1440	-	T_{Clock}
	Active	T_{HD}	-	1280	-	
	Blanking	T_{HB}	-	160	-	

Note : DE mode only

6.4.2 Timing diagram

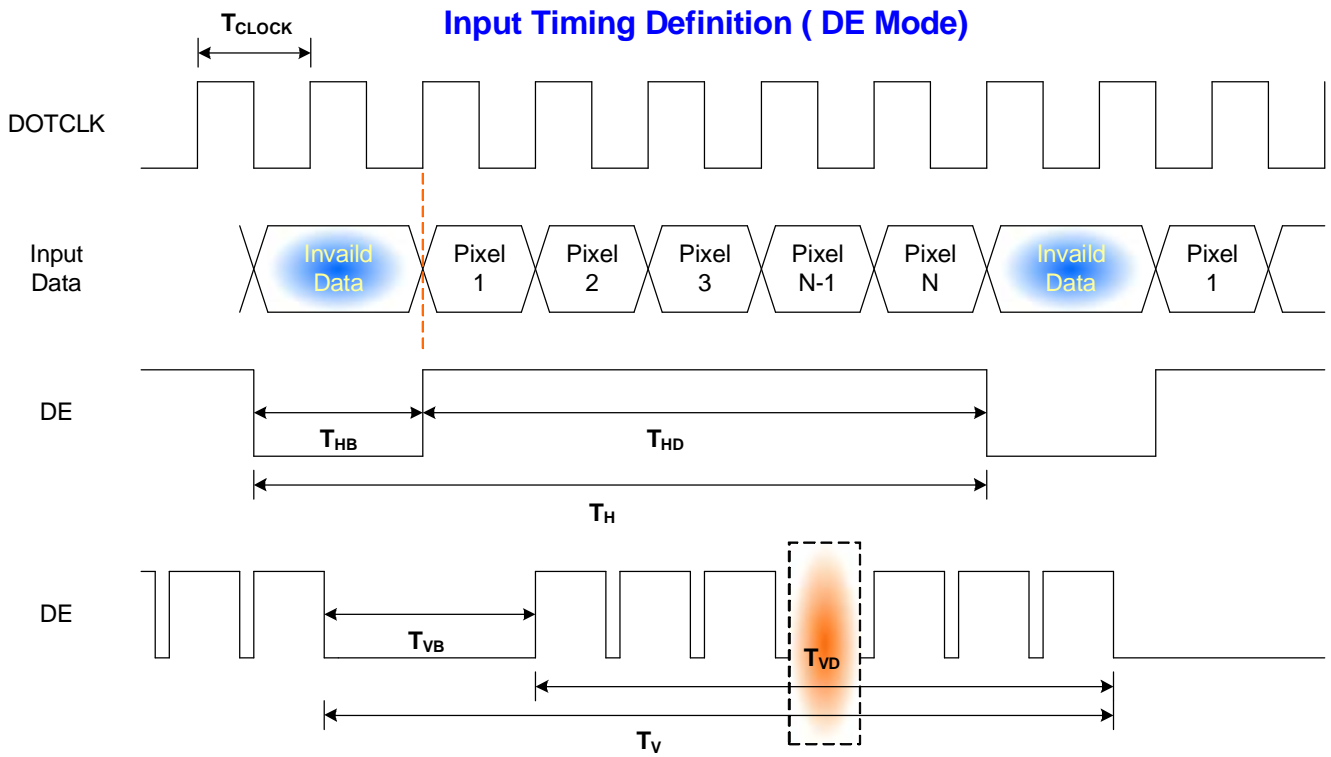

6.5 Power ON/OFF Sequence

VDD power and lamp on/off sequence is as follows. Interface signals are also shown in the chart. Signals from any system shall be Hi-Z state or low level when VDD is off.

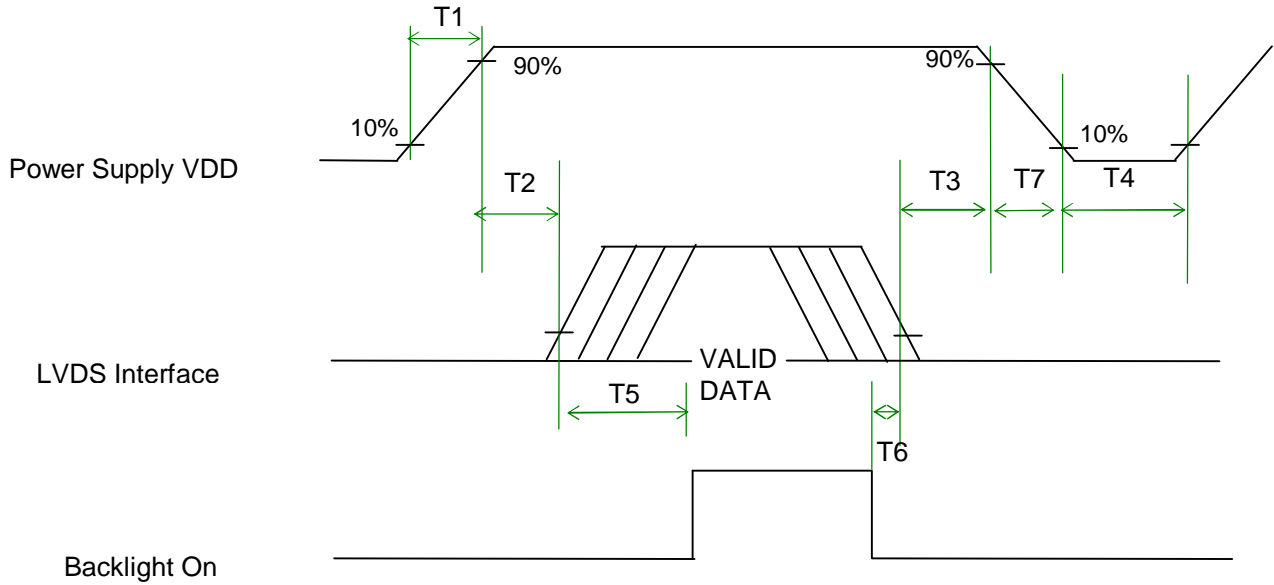

Power Sequence Timing

Parameter	Value			Units
	Min.	Typ.	Max.	
T1	0.5	-	10	(ms)
T2	0	-	50	(ms)
T3	0	-	50	(ms)
T4	400	-	-	(ms)
T5	200	-	-	(ms)
T6	200	-	-	(ms)
T7	0	-	10	(ms)

7. Connector Description

Physical interface is described as for the connector on module.

These connectors are capable of accommodating the following signals and will be following components.

7.1 TFT LCD Module

Connector Name / Designation	For Signal Connector
Manufacturer	Hirose
Type / Part Number	DF19LA-20P-1H
Mating Housing/Part Number	MSB24013P20A or compatible

7.2 Backlight Unit

Physical interface is described as for the connector on module.

These connectors are capable of accommodating the following signals and will be following components.

Connector Name / Designation	For Lamp Connector
Manufacturer	JST
Type / Part Number	BHSR-02VS-1
Mating Type / Part Number	SM02B-BHSS-1-TB

7.3 Signal for Lamp connector

Pin #	Cable color	Signal Name
1	Pink	Lamp High Voltage
2	White	Lamp Low Voltage



8. Dynamic Test

8.1 Vibration Test

Test condition:

- I Acceleration: 1.5 G
- I Frequency: 10 - 500Hz Random
- I Sweep: 30 Minutes each Axis (X, Y, Z)

8.2 Shock Test Spec:

Test condition:

- I Acceleration: 220 G , Half sine wave
- I Active time: 2 ms
- I Pulse: +/-X,+/-Y,+/-Z , one time for each side

Remark:

1. Ambient condition is $25 \pm 5^{\circ}\text{C}$, Relative humidity : 40% ~ 70%
2. Non-packaged and Non-operation



9. Reliability

Items	Required Condition	Note
Temperature Humidity Bias	Ta= 40°C , 90%RH, 300h	
High Temperature Operation	Ta= 50°C , Dry, 300h	
Low Temperature Operation	Ta= 0°C , 300h	
High Temperature Storage	Ta= 60°C , 35%RH, 300h	
Low Temperature Storage	Ta= -20°C , 50%RH, 300h	
Thermal Shock Test	Ta=-20°C to 60°C , Duration at 30 min, 100 cycles	
ESD	Contact : ±8 KV Air : ±15 KV	Note 1

Note1: According to EN 61000-4-2 , ESD class B: Some performance degradation allowed. No data lost
. Self-recoverable. No hardware failures.

Remark: MTBF (Excluding the CCFL): 30,000 hours with a confidence level 90%

10. Mechanical Characteristics

10.1 LCM Outline Dimension

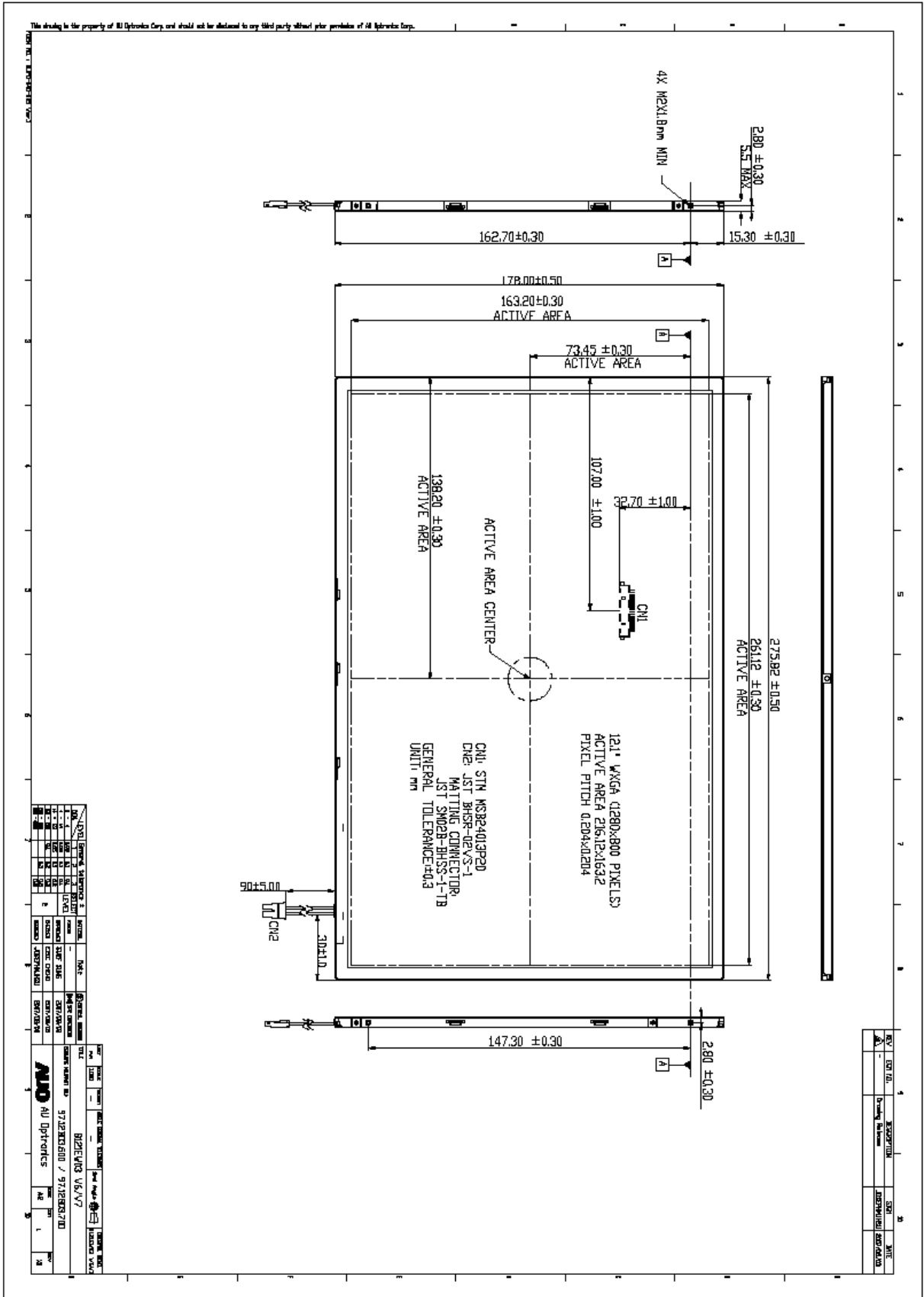



Product Specification

AU OPTRONICS CORPORATION

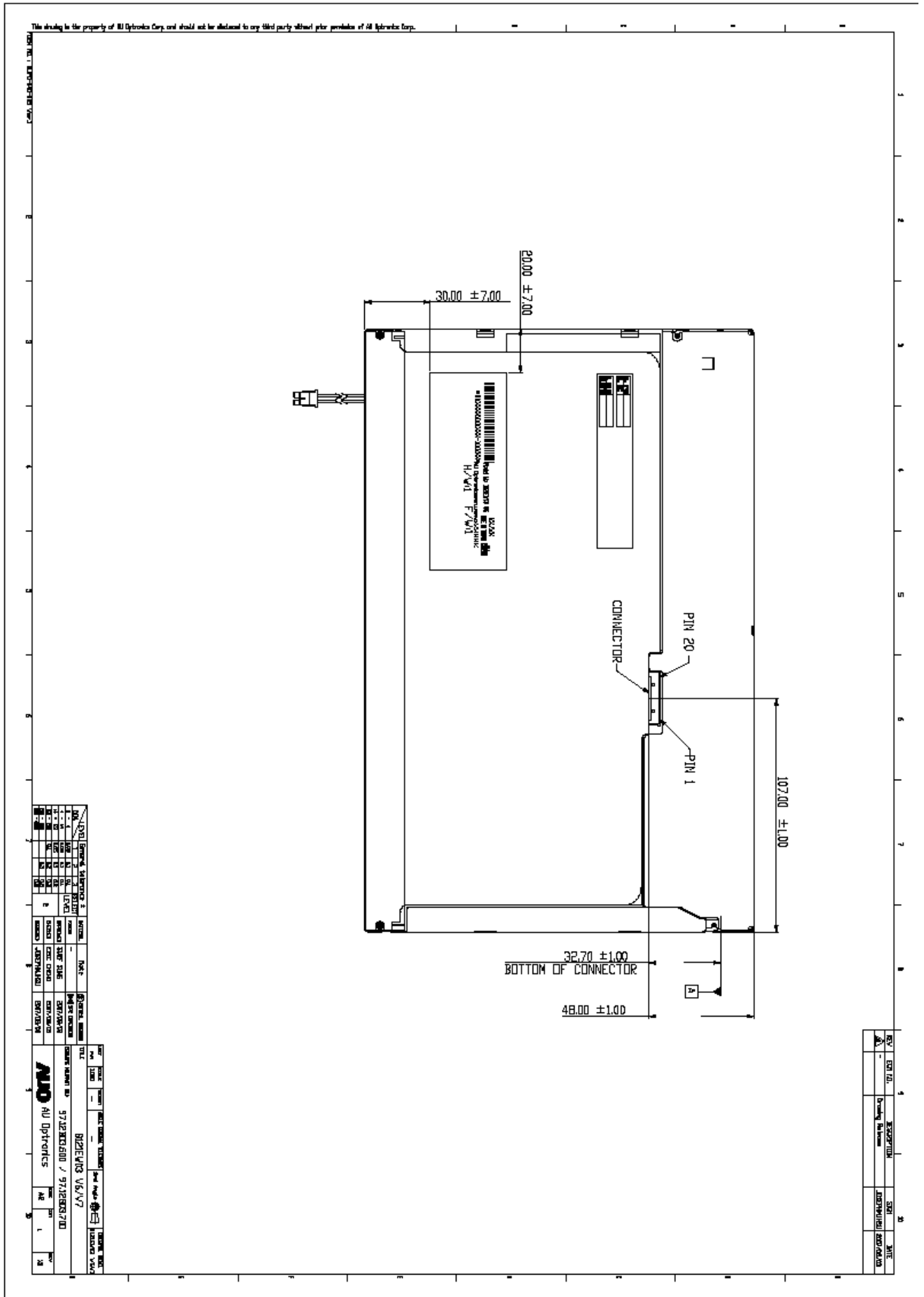



Product Specification

AU OPTRONICS CORPORATION

10.2 Screw Hole Depth and Center Position

Screw hole minimum depth, from side surface = 1.80 mm (Ref. drawing)

Screw hole center location, from front surface = 2.8 ± 0.2 mm (Ref. drawing)

Screw Torque: Maximum 2.2 kgf-cm

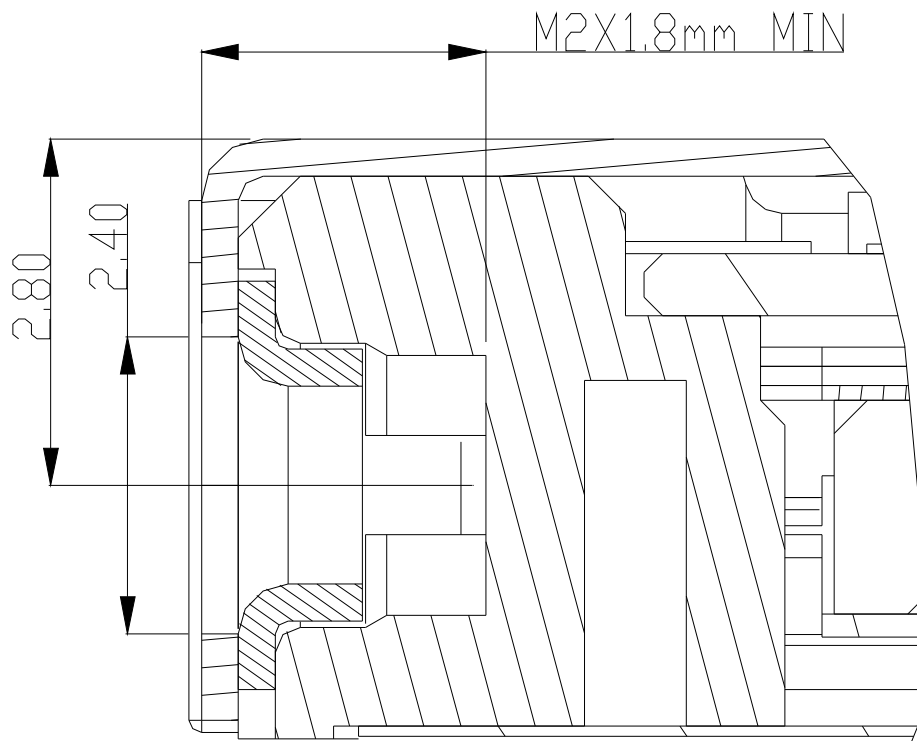

11. Shipping and Package

11.1 Shipping Label Format

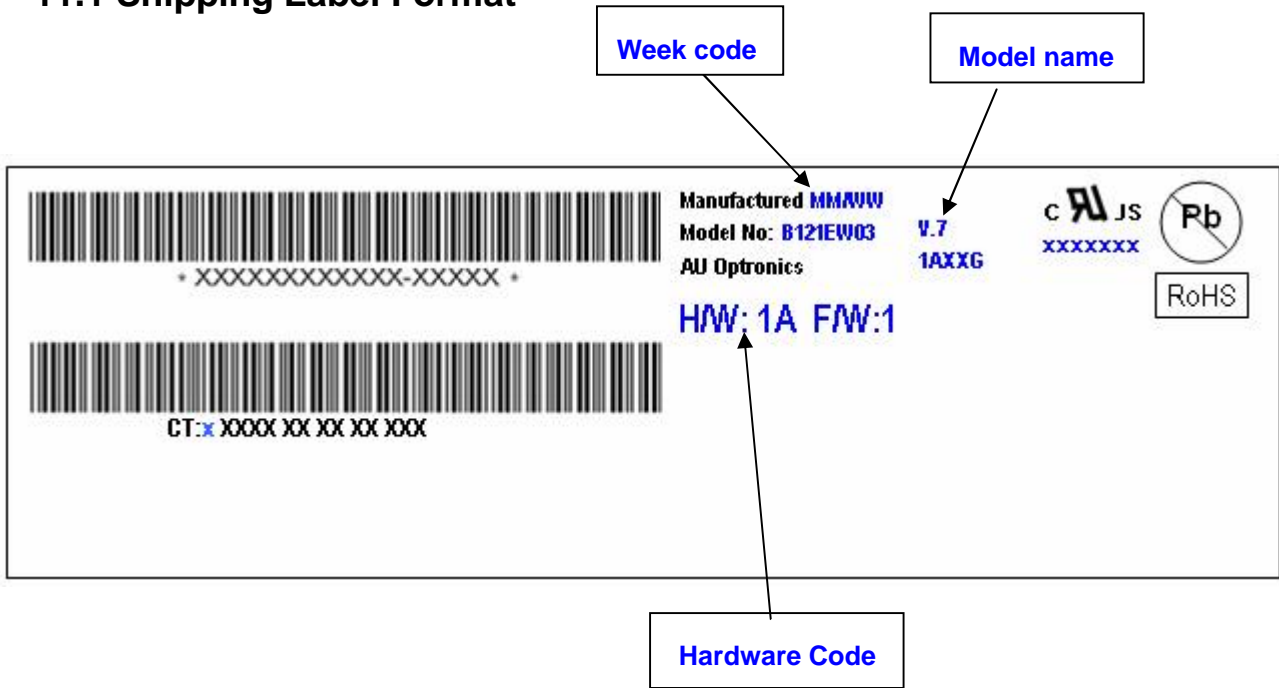

11.2 Carton package

The outside dimension of carton is 455 (L)mm x 380 (W)mm x 355 (H)mm

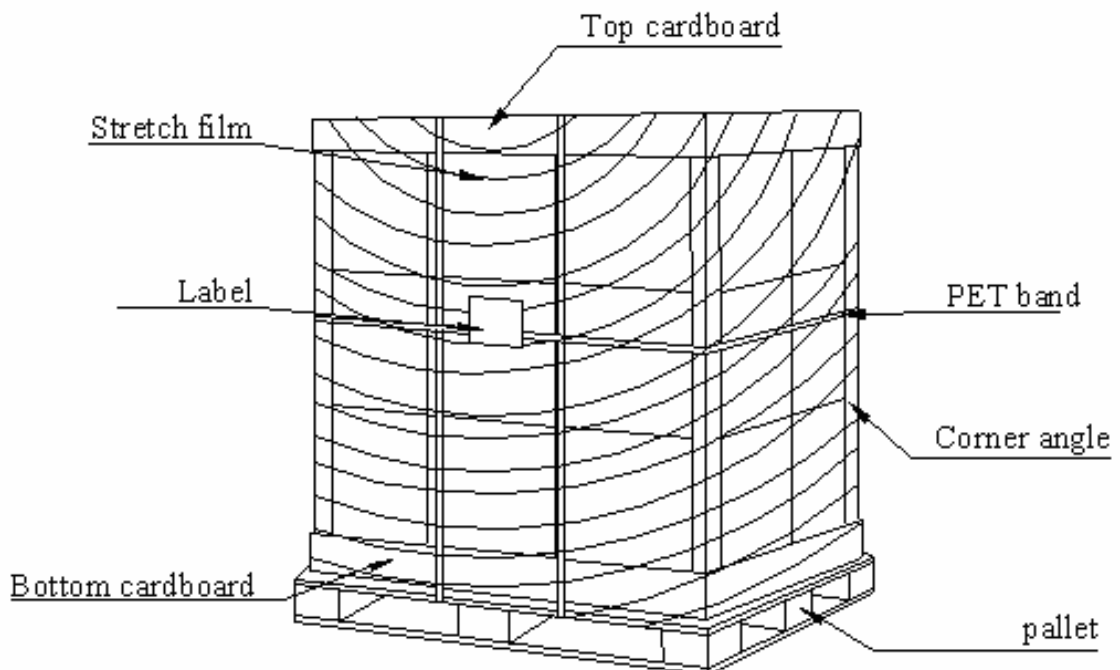
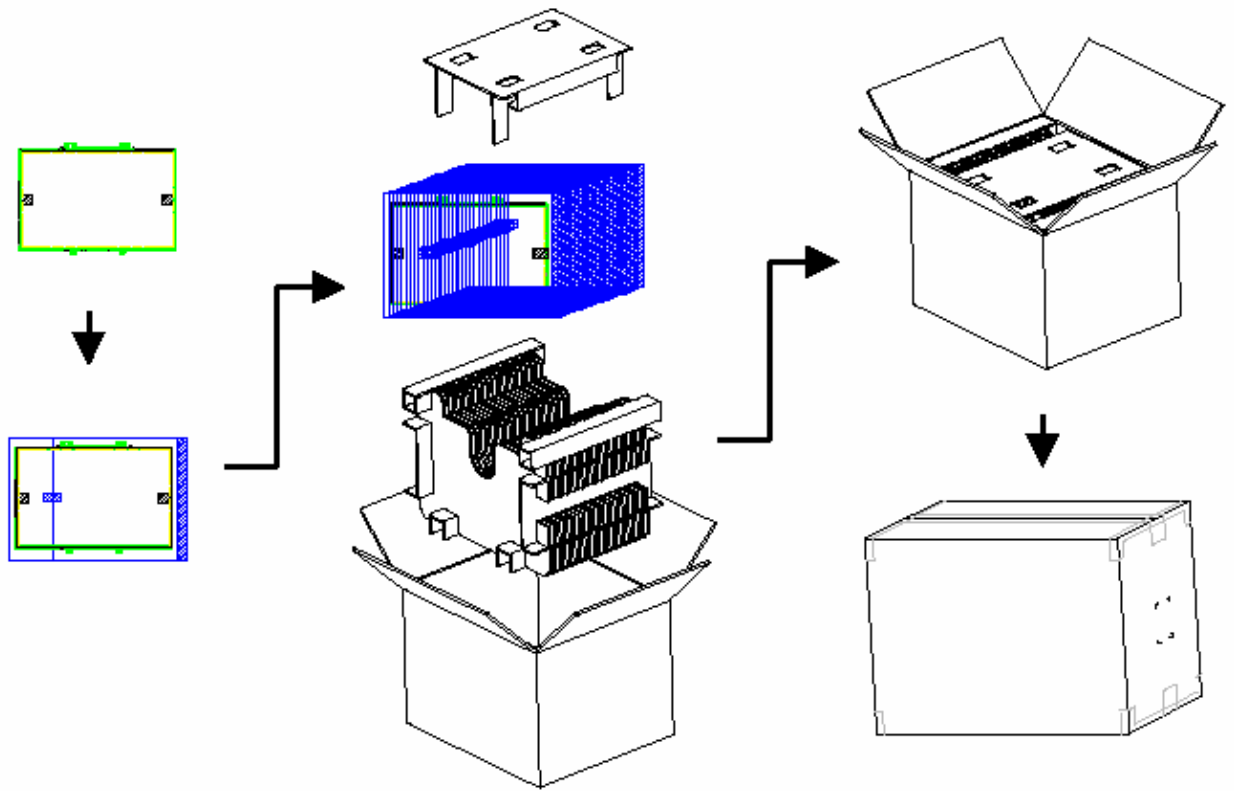



12. Appendix: EDID description

Address	FUNCTION	Value	Value	Value	Note
HEX		HEX	BIN	DEC	

TBD